

# Electrical hazards and protecting persons



06

POWER GUIDE 2009 / BOOK 06

# INTRO

**The increasing quality of equipment, changes to standards and regulations, and the expertise of specialists have all made electricity the safest type of energy. However, it is still essential to take account of the risks in all projects. Of course, expertise, common sense, organisation and behaviour will always be the mainstays of safety, but the areas of knowledge required have become so specific and so numerous that the assistance of specialists is often needed.**

---

Total protection is never possible and the best safety involves finding reasonable and well thought-out compromises in which priority is given to safeguarding people.

The safety of people in relation to the risks identified must be a priority consideration at every step of any project.

**During the design phase:**

By complying with installation calculation rules based on the applicable regulations and on each project's particular features.

**During the installation phase:**

By choosing reputable and safe materials and ensuring work is performed correctly.

**During the operating phase:**

by defining precise instructions for handling and emergency work, drafting a maintenance plan, and training staff in the tasks they may have to perform (qualifications and authorisations).

<b>Risks to people</b>	
Risk of electric shock .....	02
1. Physiological aspect .....	02
2. Protection against direct contact .....	05
3. Protection against indirect contact .....	08
Risk of burns .....	18
1. Contact with hot surfaces .....	18
2. Electric arcs .....	18
Exposure to electromagnetic fields .....	19
1. Low frequency magnetic fields (< 10 MHz) .....	19
2. Low frequency electric fields (< 1 MHz) .....	20
3. High frequency electromagnetic fields (> 1 MHz) .....	20
<b>Protection by residual current devices</b>	
Composition of residual current devices .....	22
1. Magnetic core .....	22
2. Current-sensing relay .....	22
Residual current devices .....	24
1. Determining the trip threshold .....	24
2. Choice of protection device .....	24
3. Specific conditions of use .....	27
Discrimination between residual current devices .....	30
Requirement for class II .....	30
<b>Protection provided by assemblies</b>	
Class I assemblies .....	32
1. Connection of protective conductor .....	33
2. Equipotentiality of exposed conductive parts .....	33
3. Using the exposed conductive parts as protective conductor .....	34
4. Checking the continuity of the exposed conductive parts .....	37
5. Checking resistance to overcurrents .....	37
Class II assemblies .....	38
1. Class II A enclosures .....	39
2. Class II B enclosures .....	40
3. Protective conductors (PE) .....	40
4. Checking the dielectric properties .....	41
<b>Choice of products</b>	
RCDs .....	42
RCBOs .....	43
Add-on modules .....	44

# Risks to people

Electric current is dangerous because it is invisible. Its effects on humans are sufficiently well-known nowadays for us to be able to protect ourselves effectively. The risks that may affect the installation itself and the surrounding property must form the subject of an analysis leading to the adoption of the most appropriate protection solutions.

## RISK OF ELECTRIC SHOCK

The effects of electric current on the human body depend on two factors:

- The duration of the current flow through the body
- The intensity and frequency of the current

These two factors are independent of one another, but the level of risk will be more or less high, according to the value of each factor. The intensity of the current that is dangerous for humans will depend on the voltage and the tolerance of the human body. In practice, the intensity of the current is defined based on a limit voltage  $U_L$  taken as being 50 V. This voltage takes account of the maximum current that a human being with minimum internal electrical resistance can withstand, under specific conditions. It also takes account of the maximum admissible duration of the current flow through the body, with no dangerous physiopathological effects (cardiac fibrillation).

### 1 PHYSIOLOGICAL ASPECT

When subjected to voltage, the human body reacts like a conventional receiver that has a given internal resistance. Electric current flows through it, with three serious risks:

- Tetanisation: the current keeps the muscles through which it passes contracted, and if this involves the rib cage, this may lead to respiratory arrest
- Ventricular fibrillation: this is a total disruption of the cardiac rhythm

- Thermal effects causing varying degrees of tissue injury, even deep burns in the case of high currents

The table below shows that, for a touch voltage of 220 V, a current of 147 mA will pass through the human body. This current must therefore be broken in less than 0.18 seconds to avoid any risk.

Maximum breaking time according to prospective touch voltage

Prospective touch voltage $U_c$ (V)	Electrical impedance of the human body $Z$ ( $\Omega$ )	Current flowing through the human body $I_{\Delta}$ (mA)	Maximum duration of flow $t$ (s)
$\leq 25$	(1075)	(23)	$\infty$
50	1 725 (925)	29 (54)	$\infty$ (0,48)
75	1 625 (825)	46 (91)	0,60 (0,30)
100	1 600 (800)	62 (125)	0,40 (0,22)
125	1 562 (762)	80 (164)	0,33 (0,17)
220	1 500 (700)	147 (314)	0,18 (0,05)
300	1 460 (575)	205 (521)	0,12 (0,025)
400	1 425	280	0,07
500	1 400	350	0,04

Values in brackets are for double contact, both hands, both feet (UTE C 15-413)



In some installations or under particular conditions (damp areas, moist skin, low resistance flooring, etc.) a lower impedance value can be taken into account (values in brackets in the table on the previous page).

In view of the two parameters to be taken into account for evaluating the risk, the standards define the time/current limit curves.

These curves, taken from IEC 60479-1, give the various limits of the effects of 50 Hz alternating current on humans and define 4 main risk zones.

### Time/current curves showing the effects of 15 to 100 Hz alternating current on humans

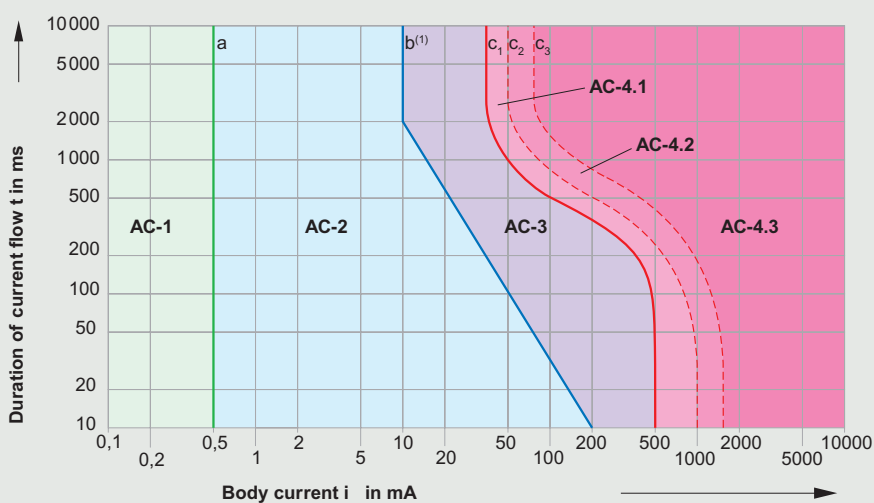

(1) If the current flows for less than 10 ms, the limit of the current passing through the body for line b remains constant at 200 mA

Zone	Physiological effects
AC-1	Generally no reaction
AC-2	Generally no dangerous physiological effect
AC-3	Generally no organic damage. Probability of muscle contractions and breathing difficulties if current flows for longer than 2 s. Reversible interference in the formation of cardiac impulse propagation without ventricular fibrillation, increasing with the intensity of the current and the flow period.
AC-4	Increasing with the current intensity and duration, pathophysiological effects such as cardiac arrest, respiratory arrest and severe burns can occur in addition to the effects of zone AC-3. AC-4.1 : Probability of ventricular fibrillation up to approximately 5% AC-4.2 : Probability of ventricular fibrillation up to approximately 50% AC-4.3 : Probability of ventricular fibrillation greater than 50%

## Risks to people (continued)

Conventional time/current zones of effects of d.c. currents on persons for a longitudinal upward current path (hand to feet)

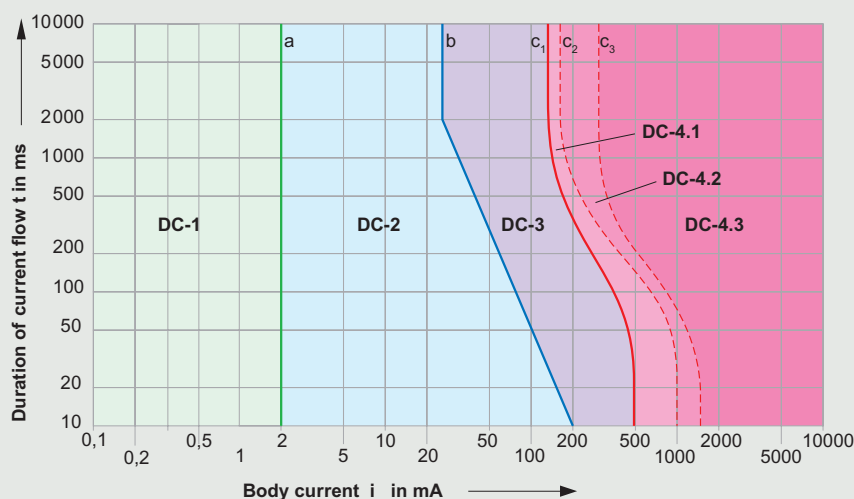

Zones	Physiological effects
DC-1	Slight pricking sensation possible when making, breaking or rapidly altering current flow
DC-2	Involuntary muscular contractions likely especially when making, breaking or rapidly altering current flow but usually no harmful electrical physiological effects
DC-3	Strong involuntary muscular reactions and reversible disturbances of formation and conduction of impulses in the heart may occur, increasing with current magnitude and time. Usually no organic damage to be expected
DC-4 <sup>(1)</sup>	<p>Patho-physiological effects may occur such as cardiac arrest, breathing arrest, and burns or other cellular damage. Probability of ventricular fibrillation increasing with current magnitude and time</p> <p>DC-4.1 : Probability of ventricular fibrillation increasing up to about 5 %</p> <p>DC-4.2 : Probability of ventricular fibrillation up to about 50 %</p> <p>DC-4.3 : Probability of ventricular fibrillation above 50 %</p>

[1] For durations of current flow below 200 ms, ventricular fibrillation is only initiated within vulnerable period if the relevant thresholds are surpassed. As regards ventricular fibrillation this figure relates to the effects of current which flows in the path left hand to feet and for upward current. For other current paths the heart current factor has to be considered



Electrical accidents cause thousands of injuries every year, involving both professionals and non-professionals. Around half of these accidents are connected with indoor low voltage installations. The other half involve a range of causes including contact with overhead lines or lightning. When electric current passes through the body the victim “cannot let go” (tetanisation of the hands on the area with which they are in contact), or the reverse happens and the muscles relax, causing him/her to be thrown back, with the associated risk of injury (falling from a ladder, etc.). Accidents are associated with carelessness, but more often than not it is the poor condition of installations or equipment which causes an unexpected electric shock. Compliance with legal obligations to ensure protection (approved equipment) is a guarantee of safety, as long as maintenance and upgrading are carried out correctly; but to date there is no legal obligation providing for this. Hence the importance of ensuring that users (which includes all of us) are aware of the risks.

## 2 PROTECTION AGAINST DIRECT CONTACT

Direct contact means when a person directly touches an energised unprotected part of a device, a piece of equipment or an installation (carelessness, clumsiness, fault, etc.). Protection against this danger can be achieved in a number of ways.

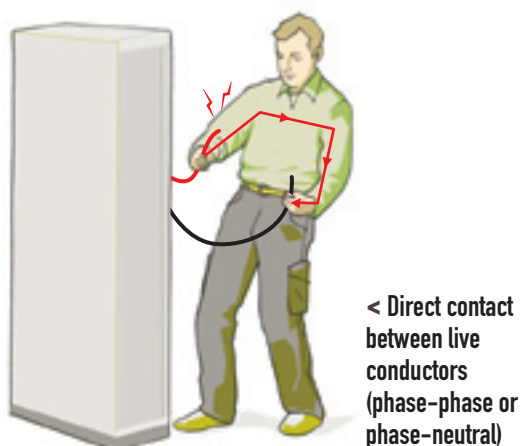
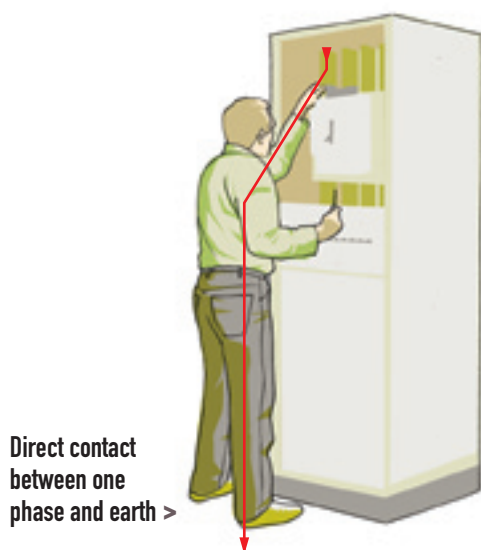

### 2.1. Protection by insulation

The live parts are covered with insulation that can only be removed by dismantling or destruction. Factory-made equipment, cables, and more generally devices for general use (tools, luminaires, etc.) are protected by insulation.



Apart from providing guaranteed insulating properties, as well as adequate and durable mechanical, chemical and thermal properties, the use of varnish, paint or any treatment is not generally permitted (other than products guaranteed by the manufacturer).

### 2.2. Protection by barriers and enclosures

The live parts are placed behind barriers or inside enclosures which provide IP 2x or xxB protection. This degree of protection is increased to IP 4x or xxD for the horizontal parts on which or above which people can walk (walkways, gratings, etc.).



The 1<sup>st</sup> number of the IP code has a dual meaning: protection against access to dangerous parts and protection against the entry of solid foreign bodies (standard EN 60529). Expressing this in the form IP 2x means that both meanings are taken into account and have been tested with different gauges: the accessibility gauge (jointed finger) for access to dangerous parts, the object gauge (ball) for the entry of solid bodies. In the case of the protection of persons, only accessibility should be verified, and expression in the form xxB is more appropriate.

## Risks to people (continued)

### Protection by barriers and enclosures

The barriers and enclosures must maintain adequate clearances from the live parts. Their removal and access to the live parts must only be possible under the following conditions:

- With a key or a tool

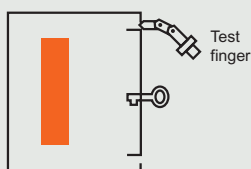

- After de-energisation of the accessible parts (automatic control by an isolating device)

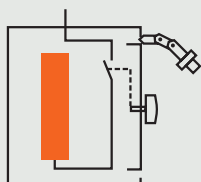

- When a second level of barrier (screen) provides IP 2x or xxB protection, it must only be possible to remove it with a key or a tool.

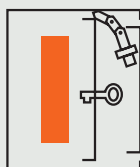

The general concept of closing using a key or a tool must be adapted to the actual requirements of the installation site



### Panels and assemblies

The absence of any standard requirements on accessibility to live parts after opening the door or removing faceplates (with a key or a tool) leads to varying interpretations.

Inspection bodies, safety departments or specifiers in their specifications often extend the need for IP xxB protection to equipment located in closed enclosures and for which protection against direct contact is therefore in theory already provided. The argument is based on the fact that these enclosures are seldom locked and that unqualified people carry out simple operations in them, such as resets.

If, basically, this requirement is justified, we must be aware that genuine IP xxB protection is inconvenient to achieve, all the more so as the power increases (connections, terminals, bars, etc.). A practical approach would therefore be to transfer the functions which need to be accessible to the front panel, a faceplate or to a dedicated enclosure.

The IP xxB requirement is not in principle necessary behind faceplates that are themselves IP xxB and can be removed using tools. Here too, it is important to be sure that the protection is total and durable: care must be taken not to give a false sense of security by the presence of elements that are presumed to be protective, but are incomplete, or even create additional risks when they are removed.

If a level of protection is specified behind faceplates for a qualified worker, IP xxA protection (50 mm sphere simulating the back of the hand) is generally adequate for protection against accidental contact. The service index (IS) may lead to higher protection levels being recommended (xxB in the work area).



## 2.3. Protection using obstacles

The obstacles consist of guardrails, grids, etc. which prevent access to the energised parts. If it remains possible to bypass the obstacles intentionally or for conductive elements to pass through them, the use of this method of protection must be limited to electrical rooms.

## 2.4. Protection by distance

If the parts are at different voltages (separate circuits, live parts and exposed conductive parts), they must be sufficiently far apart so that they cannot be accessed simultaneously. The minimum distance between the parts must be 2.5 m, and if necessary more if conductive objects (ladders, etc.) may be used nearby. This method of protection, which can be combined with the use of obstacles, is reserved for electrical rooms and overhead lines.

## 2.5. Protection by safety extra low voltage

Protection is provided by the use of a non-dangerous voltage supplied by a safety source. The upper voltage limit is 50 V (conventional limit value) but lower supply voltage values of 25 V or 12 V are used for operating conditions in damp or submerged environments. If the extra low voltage is not provided by a safety source (auto-transformers, electronic power supply, variable control unit), the circuit concerned must be subject to protective measures than other ELV, (generally the same as those of the LV supply circuit). Safety extra low voltage can provide protection against direct contact and indirect contact at the same time (cf. "Class III" p. 11).



> Legrand safety transformers: conforming to standard EN 61558-2-6, they constitute safety sources from 63 VA to 10 kVA



The safety sources are called:

- SELV (TBTS in French) if the ELV circuit is not connected to earth.
- PELV (TBTP in French) if the ELV circuit is connected to earth.

## 2.6. Protection by limiting the discharge energy

This measure is only applied to devices that comply with specific requirements and is not applicable to an entire installation. The discharge energy and current are limited as appropriate (touch-sensitive switches, electrotherapy devices, electric fences, etc.) to values that can induce variable but not dangerous sensory reactions.

## 2.7. Protection by high sensitivity residual current device

The use of residual current devices not exceeding a trip threshold of 30 mA provides additional protection against direct contact in the event of failure of the conventional methods, clumsiness or carelessness of users.

This method is not recognised as being adequate on its own, in that it only protects against contact between earth and live conductors (ph/PE) and not contact between live conductors (ph/ph or ph/N). See page 27 for recommended uses (in addition to neutral earthing systems) or uses required by regulations (power sockets, bathrooms, etc.).



< Legrand AC 30 mA RCCB, 25 to 63 A incoming and outgoing line via the top with non-screw automatic connections

# Risks to people (continued)

## 3 PROTECTION AGAINST INDIRECT CONTACT

Indirect contact refers to situations when a person touches a metal conductive part that has been accidentally energised (insulation fault on a device or an electrical machine). It will therefore be important to detect and eliminate this fault quickly, before anyone comes into contact with the metal conductive part. Protection against indirect contact is based on combining measures affecting both the characteristics of the equipment (class 0, I, II or III) and the building of the installation (automatic disconnection, additional insulation, SELV).

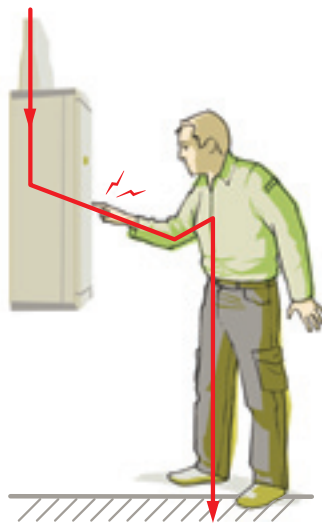

### 3.1. Classes of protection against indirect contact

#### > Class 0

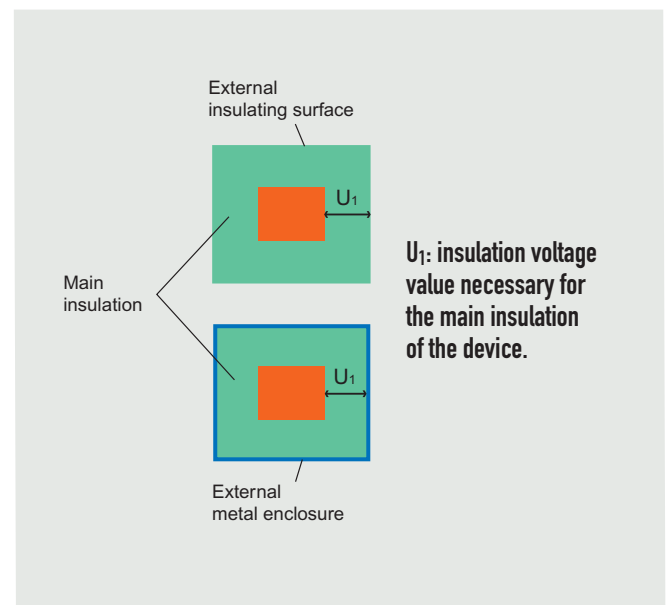

The methods of protection against indirect contact are given in standard IEC 60364-4-41 "Protection for safety - Protection against electric shock".

Standard IEC 60479-1 explains the rules with regard to the conditions of exposure and the physiological effects.

No steps are planned or taken to connect the accessible metal parts, if there are any, to a protective conductor. If there is an insulation fault, these parts may become energised.

Protection is therefore based on the impossibility of establishing contact with another voltage: a condition that can only be established in non-conductive locations (insulated rooms) or if the class 0 device is supplied via a circuit separation source.



The risk of electric shock by indirect contact is particularly pernicious as it occurs on a component (metal conductive part) that is normally quite safe, and it depends essentially on two factors that may not be seen or detected:

- The poor condition of the insulation of the device and the electrical equipment
- The absence of or a break in the protective conductor (for example, mobile device)

High sensitivity residual current devices are the most effective way of protecting against the risk of indirect contact. The generalisation of their use, including in old installations, is an unquestionable safety feature.

## > Class I

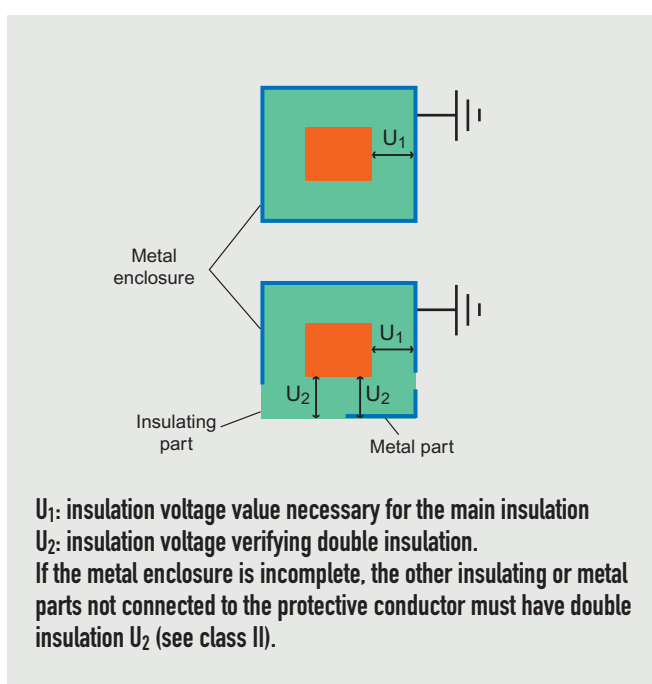

In addition to the main insulation, the protection is based on the connection of the accessible exposed conductive parts or metal parts to a protective conductor. This conductor is part of the installation and is connected to earth. Class I design assumes equipotentiality of the simultaneously accessible exposed conductive parts, continuity of the exposed conductive parts with one another, reliability of the connection devices and sufficient conductivity for circulation of the fault currents.



**Class I apparatus, devices and equipment do not provide protection against indirect contact on their own. This protection is inseparable from the measures implemented in the structure of the installation itself: creation of a fault loop, detection of this fault and breaking or limiting depending on the neutral earthing system. Principles and details of implementation are described in the book “Electrical energy supply”.**

## > Class II or double insulation

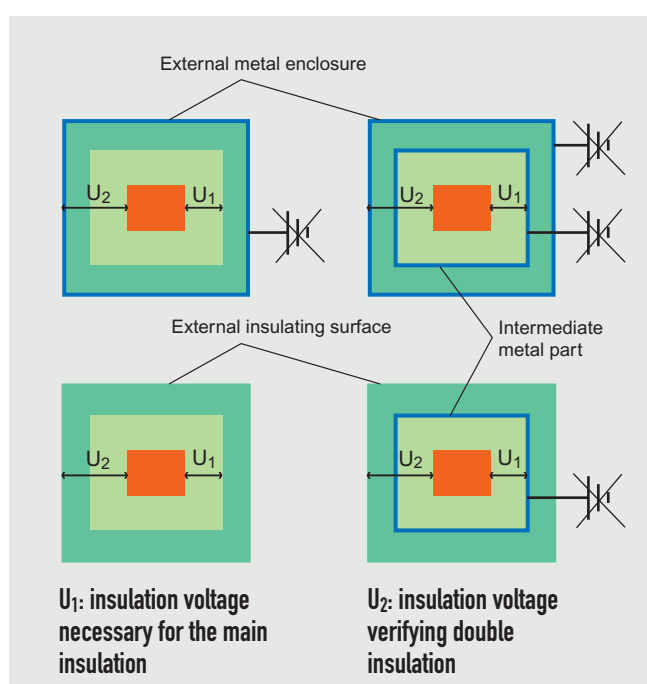

Unlike class I, protection by class II does not depend on the installation conditions. The protection is based on the low probability of a simultaneous fault of both insulations which make up the double insulation. In principle, double insulation is achieved by construction, by adding a secondary insulation (called the supplementary insulation) to the primary insulation (the main insulation). It must generally be possible for both insulations to be tested independently. If there are accessible metal parts, they must under no circumstances be connected to a protective conductor.

## Risks to people (continued)

### > Reinforced insulation

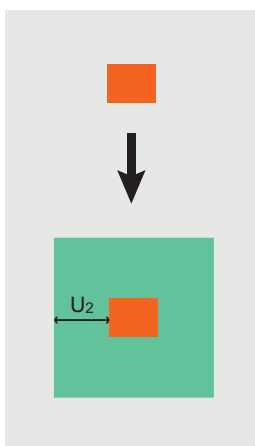

This is a variant of double insulation. It consists of single insulation, generally with the same electrical and mechanical characteristics (for example, thicker moulded insulating material). It must only be used when double insulation is not possible.

### > Equipment similar to class II by using supplementary insulation

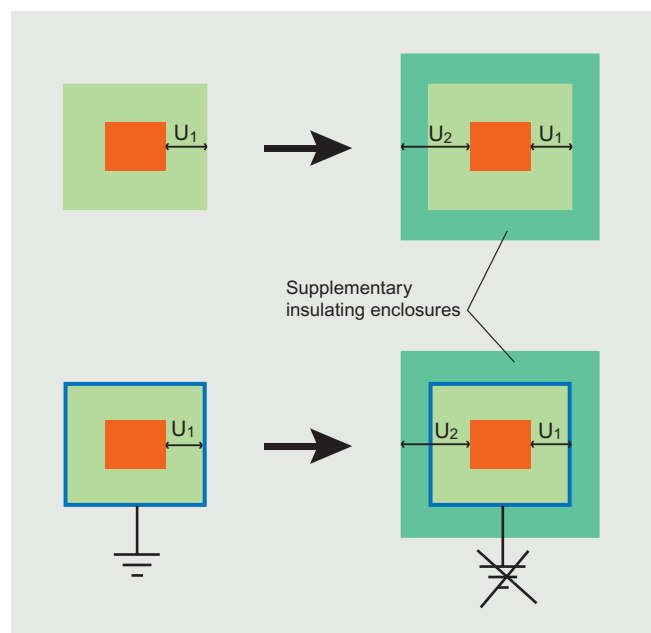

**Double insulation protection is frequently used for electrical household appliances (luminaires, domestic appliances, etc.) and for portable devices (tools). Having no protective conductor in the flexible cable avoids the risk of it breaking.**

**This concept has now changed and class II is now applied to fixed receivers (radiators for heating) and also to complete parts of installations and to distribution panels. The latter cases concern in particular the parts upstream of the protective devices which provide protection against indirect contact (cf. p. 38).**

This practice gives class 0 or I equipment class II protection conditions by adding supplementary insulation. In the latter case, the protective conductor must, of course, not be connected.

This practice can be utilised in order to:

- Use a device or item of equipment under conditions with an unsuitable environment (no protective conductor)
- Provide an insulation level equivalent to class II when building panels or assemblies.

## > Class III

This is characterised by the fact that protection against electric shocks is provided by the extra low voltage power supply (ELV range < 50 V). A class III device or item of equipment does not have an earth terminal. Apart from the exceptions provided for in the specific standard, it must not have a ground terminal (equipotential link) or functional earth (noiseless earth) either. Class III equipment that may produce voltages above the ELV range internally (for example, battery-operated TV) is not considered to be class III.

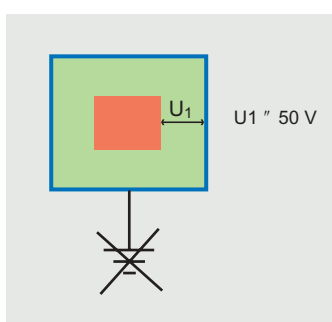

## 3.2. Protection by automatic disconnection of the power supply

The use of protective conductors linking all the exposed conductive parts of all equipment creates a circuit called the "fault loop" designed for circulation of the current that arises following an insulation fault. The fault current may or may not be carried to earth, depending on the neutral earthing system, but in all cases the objective is to keep the voltage of the exposed conductive parts to a value below the conventional limit voltage of 50 V.

The fault current value will determine the breaking device to use in each case:

- Overcurrent device to break a high current similar to a short-circuit in a TN system
- Residual current device to break a low fault current in a TT system
- No need to break the 1st fault current in an IT system, as it is very low

The application of the protective measure of disconnecting the power supply involves the use of class I equipment.

For devices, this requirement generally simply means connection of the protective conductor.

For the creation of assemblies, the application of class I construction rules must be subject to a number of precautions (cf. p. 32).



**The safety of a class III device can only be assured if it is supplied via a SELV (Safety Extra Low Voltage) safety source such as a safety transformer.**

- A SELV installation meets two criteria:
  - All the live parts are separated from the live parts of all other installations, by double or reinforced insulation
  - The live parts are isolated from earth and from any protective conductors belonging to another installation.
- A PELV (Protection Extra Low Voltage) installation is in the ELV range, but only meets the first criterion.
- A FELV (Functional Extra Low Voltage) installation is in the ELV range, but is neither SELV nor PELV.



**All the protective conductors are connected to a general equipotential link to which the metal trunking and conductive elements from outside the building are also connected. The equipotential link reduces the touch voltage in the event of a fault, whatever the earth connection scheme (neutral earthing system).**

## Risks to people (continued)

### Operating principle of protection in TT configuration

In the event of an insulation fault in a receiver, the fault current  $I_f$  (I fault) flows in the circuit called the fault loop. This comprises the impedance of the fault on the exposed conductive part of the receiver, the connection of this exposed conductive part to the protective conductor, the protective conductor itself, and its earth connection ( $R_A$ ). The loop is closed by the transformer windings and the power supply circuit. Logically, therefore, the impedance of the loop should be calculated from all of the elements in series which make up this loop.

In practice, however, and according to what the standards allow, only the resistance of the earth connection of the exposed conductive parts,  $R_A$ , is considered. This means the fault current is slightly overestimated, but the safety margin is increased. The condition  $R_A \times I_f \leq 50 \text{ V}$  must be satisfied for alternating current installations. The sensitivity threshold  $I_{\Delta n}$  of the residual current device is chosen so that  $I_{\Delta n} < \frac{50}{R_A}$ .

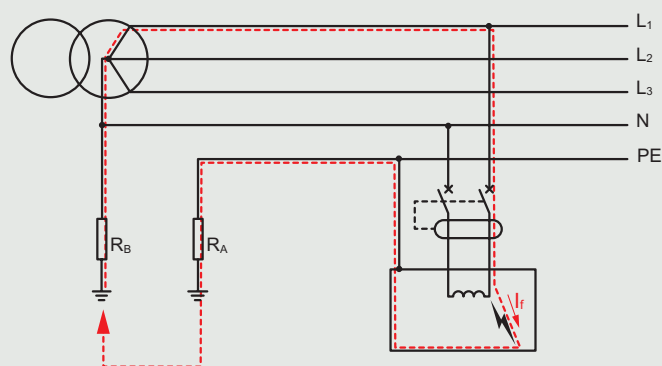

### Operating principle of protection in TN configuration

In the event of a fault at any point in the installation affecting a phase conductor and the protective conductor or an exposed conductive part, the power supply must be disconnected automatically within the specified disconnection time  $t$  and the condition  $Z_S \times I_a \leq U_0$  must be fulfilled.

$Z_S$ : impedance of the fault loop including the power supply line, the protective conductor and the source (transformer windings).

$I_a$ : operating current of the protective device in the specified time.

$U_0$ : nominal phase/earth voltage.

The maximum times should be applied to circuits that might supply Class I mobile devices (generally, all power outlets). In practice, these times are observed by the use of non-delayed circuit breakers.

For the fixed parts of the distribution installation, longer times (but below 5 s) are allowed provided that  $RPE \leq \frac{500}{U_0 Z_S}$ , where  $RPE$  is the resistance of the protective conductor (the largest value between a point of this conductor and the equipotential link).

This formula verifies that the ratio of the protective conductor's impedance to the total fault loop impedance is such that the potential of the exposed conductive part at fault will not exceed 50 V, but it does not verify that disconnection occurs within the required time limit.

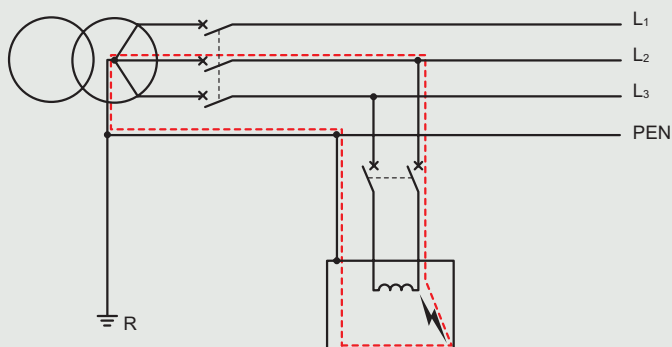

## Operating principle of protection in IT configuration

■ At the first fault, the current  $I_f$  is limited by the sum of the resistances of the power supply earth connections ( $R_B$ ), the exposed conductive parts ( $R_A$ ), and the impedance ( $Z$ ). In the example below, this gives:

$$I_f = \frac{U_0}{R_A + R_B + Z} = \frac{230}{30 + 10 + 2000} = 0,112 \text{ A}$$

The non-disconnection condition is verified, whilst ensuring that the current will not raise the exposed conductive parts to a potential greater than the limit voltage  $U_L$ . We must therefore have:  $R_A \times I_f < 50 \text{ V}$ , i.e., in the example,  $30 \times 0.112 = 3.36 \text{ V}$ .

The exposed conductive parts will not reach a dangerous voltage, and non-disconnection is authorised. To ensure continuity of operation, the fault notified by the permanent insulation controller (PIC) must be found and eliminated as quickly as possible by qualified personnel.

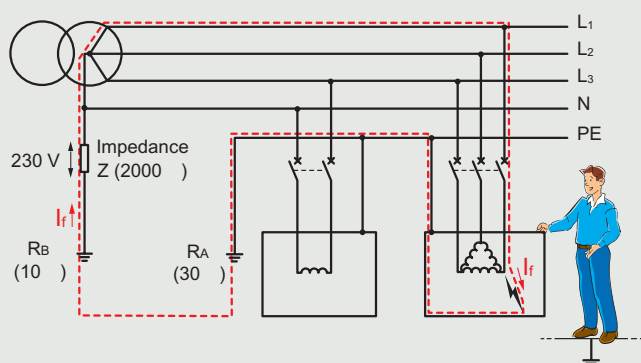

■ At the second fault affecting another phase, on the same exposed conductive part or a different one, a loop is formed by the exposed conductive parts of the receivers at fault, the protective conductors, and the supply conductors. It will result in the flow of a high current (short circuit), which can be eliminated via the conditions shown in the TN or the TT diagram. Note that this double-fault situation is totally independent of the state of the neutral with respect to earth (insulated or impeded).

The IT double-fault current is often lower than it would be in TN. The lengths of protected line are reduced accordingly. In the event of a fault, the potential of the neutral could go as high as the phase at fault (simple voltage). The potential of the other phases will tend to rise to the value of the compound voltage. That is why it is advisable not to supply devices between phase and neutral in an IT configuration and therefore not to distribute the neutral.

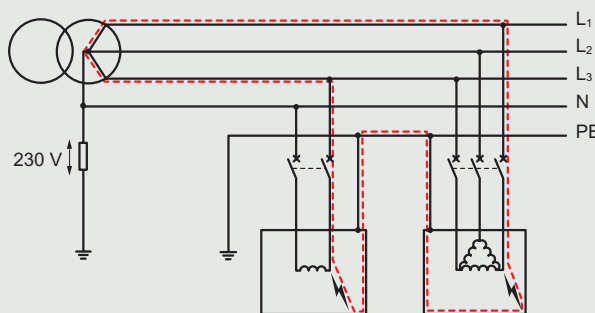

### Maximum disconnection times $t_0$ (s) - IEC 60364-4-41

System	50 V < $U_0$ ≤ 120 V		120 V < $U_0$ ≤ 230 V		230 V < $U_0$ ≤ 400 V		$U_0$ > 400 V	
	a.c.	d.c.	a.c.	d.c.	a.c.	d.c.	a.c.	d.c.
TT	0,3	(1)	0,2	0,4	0,07	0,2	0,04	0,1
TN and IT (2 <sup>e</sup> fault)	0,8	(1)	0,4	5	0,2	0,4	0,1	0,1

(1) Disconnection may be required for reasons other than protection against electric shock.

## Risks to people (continued)

### 3.3. Protection by double insulation or supplementary insulation

The risk is limited by redundancy of the insulation. Double insulation protection does not depend on the electrical organisation of the installation (neutral earthing system and protective conductors) but on the equipment alone.

It includes:

- Class II devices, marked with the symbol 0, which comply with their own standard (domestic electrical, tools, transformers, heaters, etc.)
- "Fully insulated" assemblies or panels according to standard IEC EN 60439-1 which have a continuous insulated enclosure. For domestic or terminal distribution applications, these enclosures are marked with the symbol 0. For higher powers or industrial applications, the marking is the responsibility of the installer
- Assemblies with supplementary insulation where class II is achieved, on all or part of the assembly, by structural measures taken on the installation (cf. p. 38).



> Insulated enclosure  
XL<sup>3</sup> 400 class II

### 3.4. Protection by the use of safety extra low voltage

The use of this measure against direct contact (cf. p. 07) in effect provides protection against indirect contact. Precautions must nevertheless be taken with regard to the connection of the exposed conductive parts of the ELV circuits.



**Unlike the breaking in fault or accidental contact situations by residual current devices, protection by safety extra low voltage is intrinsic to the source. It is based, amongst other things, on the clearance between the primary circuit and the secondary circuit. Only the conformity of Legrand safety transformers to standard IEC 60558-2-6 ensures the possibility of use under the most severe conditions.**

**SELV is recommended for all installations where there is a risk of damp (saunas, marinas). It must be used for hazardous working conditions (conductive enclosure, damp environment) for supplying inspection lamps, under-floor heating, etc.**





## Types of ELV circuit

### ■ SELV (safety extra low voltage) circuit:

- The live parts of SELV circuits are not connected to earth, to any other live parts, or to a protective conductor
- The exposed conductive parts of SELV circuits are not connected to other exposed conductive parts or to a protective conductor.

**NB:** If the voltage of the SELV circuit is greater than 25 V, IP xxB protection against direct contact must be provided for the energised parts.

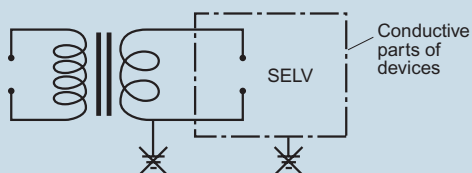

### ■ PELV (protection extra low voltage) circuit:

- A point on the secondary is connected to earth. This arrangement sets the voltage of the secondary circuit in relation to a reference, in this case, the earth. The protective conductor on the power supply of the primary can be used. Legrand transformers make this operation easier by having a PE conductor terminal near the secondary output terminals. A jumper (supplied) can be used to create the link.

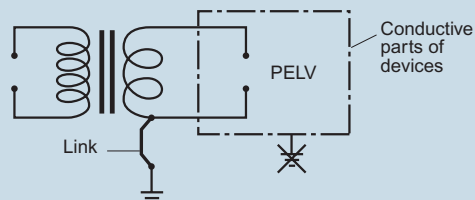

**NB:** The exposed conductive parts of the PELV circuits must not be connected to a PE conductor or to any other exposed conductive parts, which are themselves connected to a PE conductor. If this were to happen, protection against indirect contact would no longer be provided by the ELV but by the measures taken for these other exposed conductive parts (neutral earthing systems, residual current device, class II, etc.).

- FELV (functional extra low voltage) circuit: use of ELV when it is not dictated by safety but is used for functional reasons (transformation of voltage to adapt it to the characteristics of the devices supplied, for example 24 V indicator).

## Risks to people (continued)

### 3.5. Protection by electrical separation

The load circuit is separated from the supply circuit by a circuit separation transformer so that no dangerous voltage can appear between the separated circuit and earth if there is a fault. Use of protection by separation is generally limited to a single device.

The live parts of the separated circuit must not be connected to any other circuit and must have no point connected to earth. The exposed conductive parts of the separate circuit must not be connected to other exposed conductive parts or to a protective conductor. When a separate circuit supplies a number of devices, the exposed conductive parts of these devices must

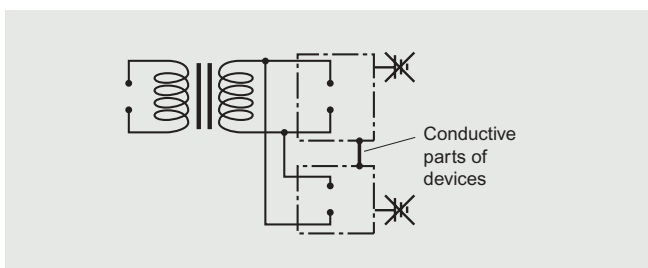

be connected to one another by equipotential bonding conductors that are not connected to earth.

If the secondary circuit covers a large area, it is recommended that the protective measures specific to creating a isolated block are applied, with a specific neutral earthing system.



**The separation of circuits enables devices in reduced insulation conditions to be supplied:**

- Area 2 in bathrooms with limited power (shaver sockets)
- Area 3 in bathrooms and swimming pools
- Portable tools and measuring equipment in site installations

Beyond the standard power range of circuit separation transformers (2500 VA single phase and 4 kVA 3-phase), the separation source can consist of isolation transformers conforming to standard IEC 60076-11.



### Other uses of circuit separation

#### ■ Unmonitored installations

Circuit separation avoids the disconnection of certain equipment in the event of a fault: freezer, safety installations, transmission equipment, alarm devices, markers, etc.

#### ■ Exemption from protection against overloads for safety reasons

Certain transformers can be built to be resistant to overcurrents and do not need, subject to sizing of the lines, to be equipped with protective devices, the use of which is recommended for certain types of application: supply of electromagnets for lifting and handling, machine excitation circuits.

#### ■ Protection against overvoltages

By isolating the load device from the supply circuit, the circuit separation transformer significantly reduces the risks of damage connected with common mode

overvoltages, which are generally the most frequent (lightning or switching).

#### ■ Protection against conducted electromagnetic interference

The separation transformer is, like protection against overvoltages, a simple, efficient and cost-effective way of limiting the propagation of interference in the most common frequency spectrum (up to 10 MHz).

Legrand can provide appropriate transformer attenuation performance levels (expressed in dB as a function of the frequency), and design and supply suitable products (equipped with shields for example). The principles for evaluating this type of use of transformers and the performance levels offered are described in the book "Protection against external disturbances".

### 3.6. Protection in non-conductive locations

This protective measure is based on the impossibility of simultaneous contact between two exposed conductive parts or between an exposed conductive part and a conductive element. The result of this is that the floor and walls must be insulated and that the room or the location must not contain any conductive elements. This measure is no longer used in residential rooms with insulated flooring (parquet, carpet) due to the uncertainty of the durability of the insulation conditions. It is an additional measure in laboratories and electrical testing areas.

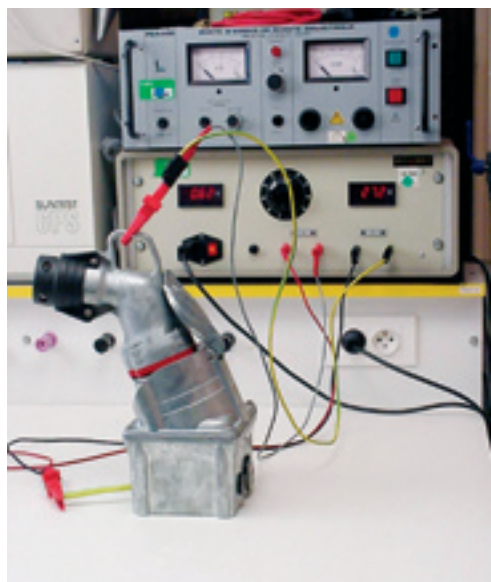

### 3.7. Protection by local equipotential link not connected to earth

All the exposed conductive parts that are simultaneously accessible are linked so that no dangerous voltage can appear between them. In practice, this measure is used for certain workstations, small area measuring benches or in standalone installations where connection to earth is not necessary or not required (see EMC and neutral earthing system in the book "Electrical energy supply").

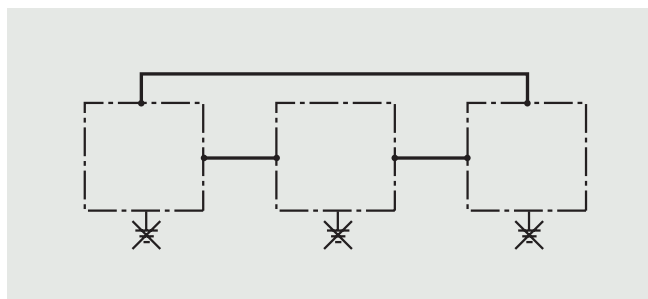

The local equipotential link that is created must not be connected to earth. Unlike an additional equipotential link, its aim is not to guarantee breaking conditions following a fault, but to ensure that all the exposed conductive parts that are accessible at the same time are at the same voltage. The sizing practices and conditions are described in the book "Electrical energy supply" (structure of the protection system).

# Risks to people (continued)

## RISK OF BURNS

### 1 CONTACT WITH HOT SURFACES

The temperatures reached by accessible surfaces on electrical equipment must not be likely to cause burns when touched.

If the surfaces have to reach higher values, even for short periods, they must be protected.



**The actual risk of burns must be evaluated, taking the following into consideration:**

- The temperature of the surface
  - The material of which this surface is made
  - The duration of contact with the skin
- Additional information, such as shape (grooves), the presence of a coating, or contact pressure, may be necessary.

European standard EN 563 on “temperatures of touchable surfaces” gives information on limits based on ergonomic data.

### Maximum permissible surface temperature values in accordance with IEC 60439

Accessible parts	Materials of accessible parts	Maximum temperatures <sup>(1)</sup>
Manual control devices	Metal	55°C
	Non-metallic	65°C
Designed to be touched, but not held in the hand	Metal	70°C
	Non-metallic	80°C
Not designed to be touched in normal operation	Metal	80°C
	Non-metallic	90°C

(1) at an ambient temperature of max. 40°C

### 2 ELECTRIC ARCS

Apart from very damaging consequences on equipment, the dangers of an accidental electric arc are above all thermal (direct burns by plasma, projection of molten material) and light-related (intense flash).

The arc may arise from the breaking or making of a circuit or from a short-circuit. In the second case, it may be extremely high-energy as it is only limited by the power of the source.



**There is no specific protection against electric arcs, which are an unforeseeable phenomenon. Shields or partitioning can limit their consequences, but the best prevention is to follow “good professional practice” and comply with regulations when creating installations.**

**The parts of installations that are not protected (upstream of the protection devices) must in particular be subject to special precautions so as to reduce the probability of a short-circuit.**

## EXPOSURE TO ELECTROMAGNETIC FIELDS

Historically, electromagnetic fields arising in industrial environments were mainly low-frequency because they were linked to the use of electrical energy (50 Hz) for its motive force or its heating capacity. Exposure limits were designed to protect against effects on the cardiovascular system (very low frequencies) and the central nervous system. The exposure situation, described as near-field, led to the electric (E) and magnetic (H) components of the signal being distinguished within the transition distance (energy balance between E and H). Today, the expansion of digital technology requires looking also at much higher frequency levels (see point 3 on page 20), the physiological effects of which are different and not yet entirely understood.



**As yet, regulations on exposure to low frequency electromagnetic fields have not been harmonised internationally. Numerous epidemiological studies have been carried out and have reached conclusions that are at times contradictory or even controversial. A great many documents (articles, theses, more or less official reports, etc.) are available on the subject. The work of the ICNIRP (International Commission on Non-Ionising Radiation Protection) was used as the basis for drawing up the EU Council Recommendation of 12 July 1999 on limiting public exposure to electromagnetic fields. In the professional field, European directive 2004/40/EC of 29 April 2004 introduced exposure limit values for workers.**

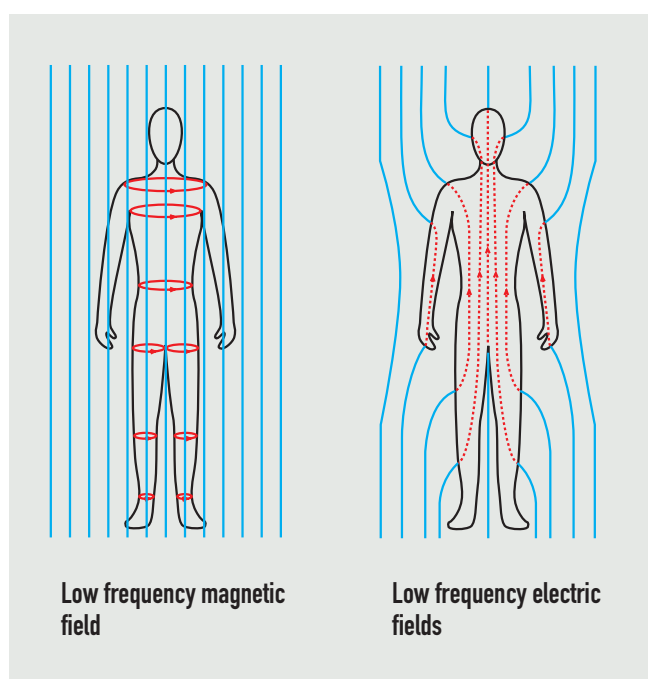

### 1 LOW FREQUENCY MAGNETIC FIELDS (< 10 MHz)

These are generated by currents and are proportional to the intensity of the currents. They induce currents in the body that are perpendicular to the magnetic field. The values of the magnetic field vary from a few pT (picotesla) to a few mT (millitesla). The exposure value decreases very quickly with the cube of the distance. The highest exposures can therefore be reached with domestic appliances used very close to the body (hairdryers, razors, electric blankets).

# Risks to people (continued)

## 2 LOW FREQUENCY ELECTRIC FIELDS (< 1 MHz)

The electric field is modified on the surface of the human body according to the body's conductivity. The intensity of the field is at its maximum at the head. The electric field induces currents more or less directly in line with the body.

The values are at their highest near high voltage power lines and transformers, welding machines and induction furnaces (up to several kV/m). The electric field decreases with the square of the distance. Information technology in the broadest sense (voice, data and image transmission), mobile telephony, TV, etc. have extended the spectrum of use towards high frequencies in all areas of daily life: private, public and the workplace.



**People with active or passive medical implants must inform the company doctor of this situation so that the actual exposure conditions (magnetic field and electric field) and their compatibility can be checked.**

## 3 HIGH FREQUENCY ELECTROMAGNETIC FIELDS (> 1 MHz)

Here we are entering the frequency range in which the transition distance between near field and far field is fundamental. Above this distance, the electric and magnetic components are combined; this is referred to as plane wave. This is generally the situation in relation to a fixed transmitter (relay). Below this distance, the E and H fields must be analysed separately. This is the situation with transmitters which are very close, like the mobile phone when it is pressed to the ear.

In these frequency ranges, the limits that are set are designed to prevent generalised or localised thermal stress of the body, which would lead to excessive heating of the tissue. Reference is made to the SAR

(Specific Absorption Rate) which is defined as the amount of energy in a given time (in other words, the power) absorbed per unit mass of tissue. It is expressed in W/kg. The value permitted for the limbs (20 W/kg) is for example higher than that for the trunk and the head (10 W/kg).

### Propagation of electromagnetic radiation

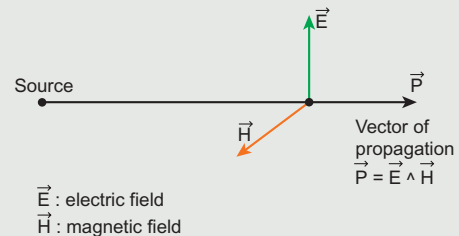
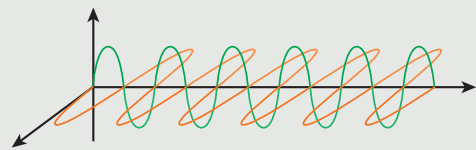

#### High impedance source

=> high voltage  
 => electric field

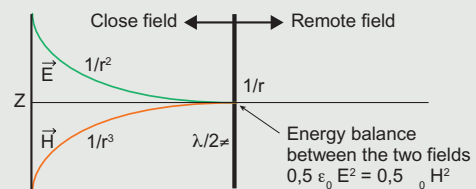

#### Low impedance source

=> high current  
 => magnetic field

$$Z = \frac{E}{H} = \sqrt{\frac{\epsilon_0}{\mu_0}} = 377 \Omega$$

$$\mu_0 = 4 \pi \cdot 10^{-7} \text{ H/m (magnetic constant)}$$

$$\epsilon_0 = \frac{1}{36 \pi \cdot 10^9} \text{ (electric constant)}$$



## Biological effects and health effects

The biological effect represents the body's sensory response to a stimulus. It is not necessarily dangerous to health: sweating (biological sign) can characterise fear. Electromagnetic fields cause biological effects: they are connected with the induction of currents in the body, and the appearance of thermal effects. To date, undesirable health effects due to exposure to non-ionising electromagnetic fields, even for prolonged periods, have never been proved. The recent use of complex signals: pulsed, multifrequency, transient, and also, somewhat paradoxically, continuous exposure to very low levels (for example, in the home) have rekindled study and debate. But here too, it is important not to confuse biological effects and health effects, even though in our continuing state of relative ignorance of so wide and complex a subject, prudence must prompt a little common sense in everyone's behaviour.



## Ionising and non-ionising radiation

Of the types of radiation which make up the magnetic spectrum only those with the highest frequencies (cosmic rays that do not reach earth, gamma rays emitted by radioactive sources and X rays) have the property of being able to break chemical bonds. They are said to be "ionising". Electromagnetic fields originated by man (industrial activity, radio transmissions and communications, and even microwave frequencies of radar systems) are in relatively low frequency ranges in relation to the whole range of the electromagnetic spectrum. The quantum energy they carry is not capable of breaking intramolecular bonds: they are said to be "non-ionising".

## Electromagnetic spectrum

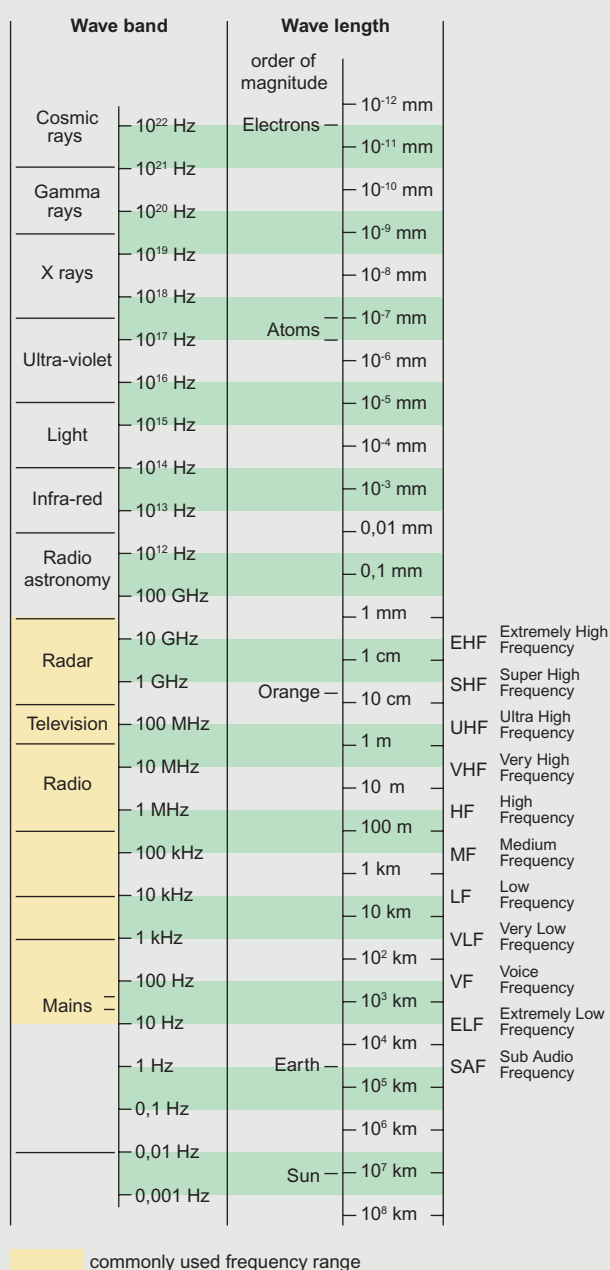

# Protection by residual current devices

The main function of residual current devices is to provide protection against indirect contacts. High sensitivity models also contribute to ensuring protection against direct contacts.

Residual current devices continually measure the difference between the value of the outgoing and incoming currents in the circuit they are protecting. If this difference is not equal to zero, that means there

is a leakage current or a fault current. When this current's value reaches the residual current device's set threshold, it automatically cuts off the circuit's power supply.

## COMPOSITION OF RESIDUAL CURRENT DEVICES

The residual current device consists principally of a core and a current-sensing relay.

### 1 MAGNETIC CORE

The magnetic core works like a transformer. The primary measures all the currents on the circuit being monitored, the secondary powers the current-sensing relay. If there is a leakage or fault current, the vectorial sum of the currents is not zero and results in a residual current. Above the preset threshold  $I\Delta n$ , the current-sensing relay controls opening of the main contacts of the associated breaking device (switch or circuit breaker).

### 2 CURRENT-SENSING RELAY

The current-sensing relay consists of a magnetised coil which, as long as no fault current is present, holds an armature in the closed position. This armature is fixed on a shaft and is subject to force from a spring. As long as the coil is not excited by a current, the permanent magnet provides an opposing force holding the armature in place which is greater than the force of the spring. If the coil is excited, the induced magnetic flux opposes the permanent magnetisation. The force generated by the spring then causes the armature which controls the contact opening mechanism to move.

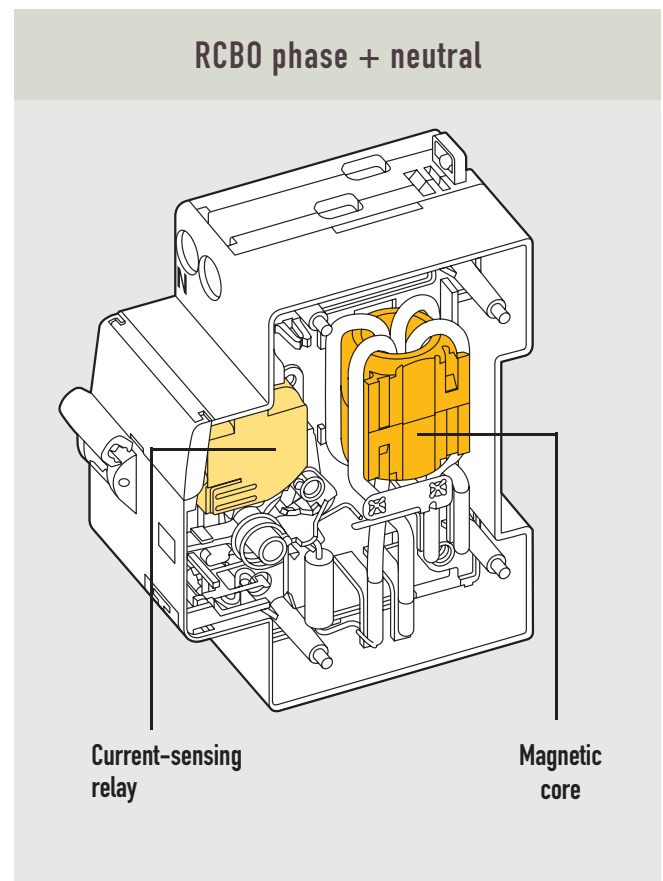

### Leakage current and fault current

■ **Leakage current:** Current that flows to earth when there is no fault in normal operating situations.

■ **Fault current:** Current that flows to earth via the exposed conductive parts or the protective conductor following an insulation fault.



## Operating principle

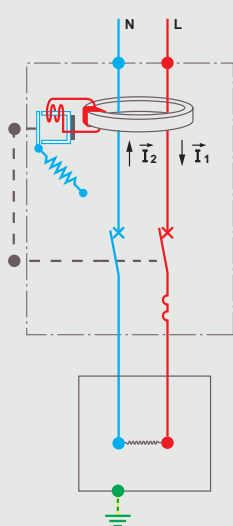

$$\vec{I}_2 = -\vec{I}_1$$

$$\vec{I}_1 + \vec{I}_2 = 0$$

The value of the outward current (phase) is the same as the value of the return current (neutral). If there is no residual current, no magnetic flux is created in the core. The current-sensing relay coil is not excited. The contacts remain closed. The device works normally.

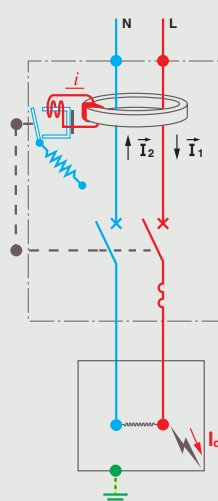

$$\vec{I}_2 \neq \vec{I}_1$$

$$\vec{I}_1 + \vec{I}_2 = \vec{I}_d$$

The value of the outward current (phase) is different from the value of the return current (neutral). The residual current causes magnetic flux in the core, which generates a current that will excite the current-sensing relay.

For three - or four - pole residual current devices, all the conductors (phases and neutral) go into the core.

### Caution:

- The neutral conductor must always go through the residual current device
- The PE conductor must never go through the residual current device

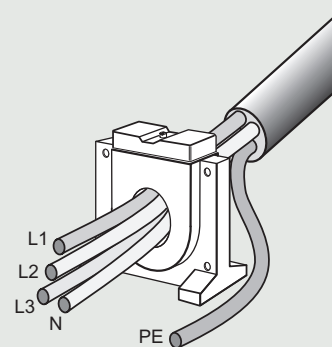

### > At the first fault, in a TT configuration

- Placed at the front end of an installation, the residual current device will detect fault currents as soon as they arise. It also means that hard-to-obtain earth connection values need not be demanded.
- Placed on each outgoing feeder or each group of circuits, it means that protection can be discriminating if the exposed conductive parts are not interconnected.

### > At the first fault, in a TN configuration

- Placed on each outgoing feeder, it guarantees the tripping conditions in the event of excessive line lengths and poorly controlled usage.

- Placed at the head of a group of circuits, it provides protection when the exposed conductive parts are not interconnected (separate buildings, remote use).

### > At the second fault, in an IT configuration

- Placed on outgoing feeders whose conditions do not guarantee protection (line lengths often limited in IT by a lower fault current than in TN), it guarantees disconnection.
- Placed at the head of a group of circuits, it provides protection when the exposed conductive parts are not interconnected (separate buildings, remote use).

# Protection by residual current devices (continued)

## RESIDUAL CURRENT DEVICES

The choice of a residual current device depends on the required level of protection (trip threshold sensitivity  $I\Delta n$ ), on the nature of the associated breaking device (circuit breaker or switch) and the specific conditions of use (delayed, discriminating, immune).

### 1 DETERMINING THE TRIP THRESHOLD

There are three families of residual current devices, referred to as high, medium and low sensitivity.

#### 1.1 High sensitivity: $I\Delta n \leq 30 \text{ mA}$

These are used on power socket circuits, in damp rooms, mobile installations (building sites, fairs, etc.), agricultural buildings or when the earthing conditions are defective.

#### 1.2 Medium sensitivity: $30 \text{ mA} < I\Delta n \leq 500 \text{ mA}$

These are used on the circuits of fixed installations (principally on TT systems). They provide discrimination with high sensitivity devices. They ensure protection under minimum short circuit conditions (lengths of lines in TN and IT systems) and limit the fault currents (risk of fire).

#### 1.3 Low sensitivity: $I\Delta n > 0.5 \text{ A}$

Used in TN and IT systems, these provide discrimination with high and medium sensitivity devices.

### 2 CHOICE OF PROTECTION DEVICE

#### 2.1 Residual current device without overcurrent protection (RCCB)

Conforming to standard IEC 61008, this breaks the circuit but does not provide protection against overcurrents. A protection device, such as a circuit breaker or fuse, must therefore be used with it, which will also protect the RCBO.

#### 2.2 Residual current device with overcurrent protection (RCBO)

Conforming to standard IEC 61009-1, this both breaks the circuit and protects against overcurrents (short-circuits and overloads). It is available in several forms:

- Modular monobloc
- Add-on module for modular device
- Associable add-on module (vertical or horizontal) for DPX
- Residual current relay with separate core used with a circuit-breaker



^ 4P RCCBs: neutral on right-hand side or on left-hand side

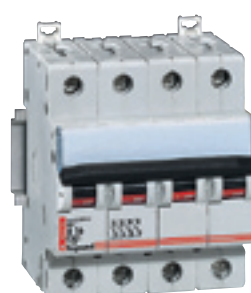

^ Four-pole monobloc RCBOs with 4 modules only up to 32 A



^ Add-on module for modular circuit breakers

**! RCCB upstream of the overcurrent protection devices**

The part of installations between the RCCB upstream and the protective devices downstream must be subject to precautions that are designed to reduce the risks of indirect contact (wiring in ducting, attached wires, busbars, Lexiclic distribution block).

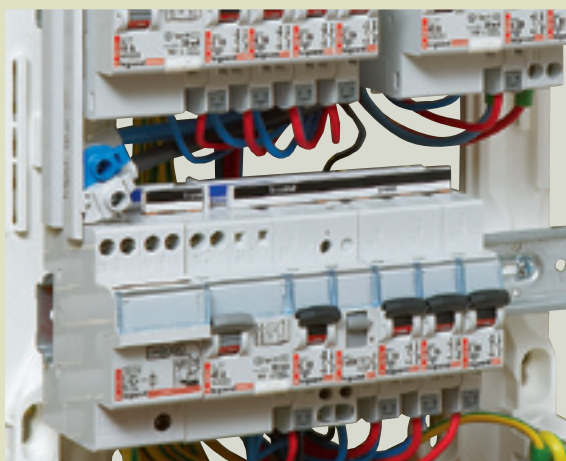

The combination of splitter busbar and vertical prong-type supply busbar enables supply via a voltage surge protector protected by the RCCB and beyond the row...

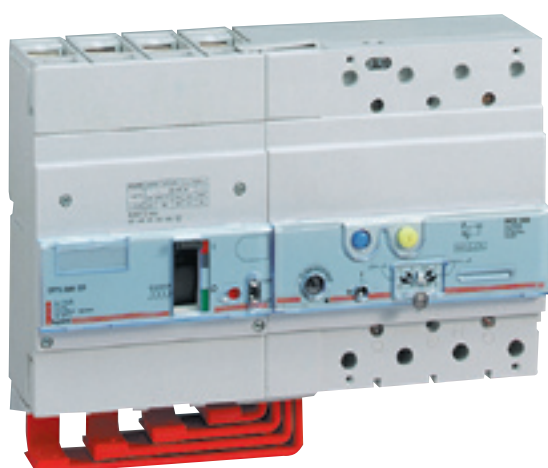
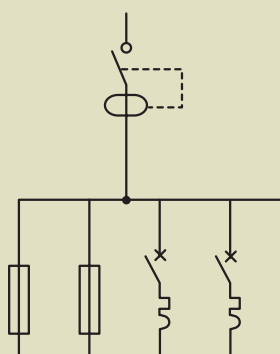

^ Side-mounted add-on module combined with a DPX 250 ER

**Residual current relays with separate core**



This adds a residual current function to DPX and DMX circuit breakers and switches equipped with trip coils.

# Protection by residual current devices (continued)



## Additional protection against direct contact in residential premises in France NF C 15-100 part 7-771

All the circuits in the installation must be protected by 30 mA RCDs, the minimum number of which is defined as follows:

Single phase power connection: 18 kVA, with or without electric heating	
Residential premises	Minimum nominal current $I_n$ of the 30 mA RCCBs
Area $\leq 35 \text{ m}^2$	1 x 25 A and 1 x 40 A <sup>(1)</sup>
$35 \text{ m}^2 < \text{Area} \leq 100 \text{ m}^2$	3 x 40 A <sup>(1)</sup>
Area $> 100 \text{ m}^2$	4 x 40 A <sup>(1) (2)</sup>

(1) A 40 A RCD will be type A to protect in particular the specialised cooker or hob circuit and the specialised circuit for the washing machine(2) If there is electric heating with a power greater than 8 kVA, replace a type AC 40 A RCD with a type AC 63 A RCD

If RCBOs are used, the minimum number is identical, but their rating is adapted to the circuit to be protected. Residual current protection devices must be placed at the source of each circuit, except for those supplied by a separation transformer.

The protection of the external circuits supplying installations and equipment not fixed to the building must be separate from those of the internal circuits.

Protection by 30 mA RCD can be:

- either a branch device for a group of circuits
- or an individual device for a specialised or non-specialised circuit

Specialised circuits may be used for the most probable sources of tripping, such as washing machines or dishwashers.

Uses where breaking must be avoided (freezers, microcomputing) can be protected by RCDs with reinforced immunity (Hpi) or by a separation transformer.



Residual current devices are equipped with a “test” button. This simulates a fault current. A test must be performed once a month.



Residual current trip thresholds are usually guaranteed for a low temperature down to  $-5^\circ\text{C}$ .

For some versions, in particular “Hpi”, they are guaranteed down to  $-25^\circ\text{C}$ . This is indicated by special marking.



### 3 SPECIFIC CONDITIONS OF USE

There are two types of residual current device:

> **Type AC**

Used for standard applications with no DC components present.

> **Type A**

Used when the loads distort the signal (the current is not a perfect sine wave or has a DC component). They are recommended for the protection of electronic equipment, computers, or fluorescent devices etc.

Each type of residual current device is available in:

> **“Standard” version**

Tripping is deemed to be instantaneous.

> **“S” version (discriminating or delayed)**

Tripping is delayed to enable discrimination with other downstream residual current devices.

There is a variant of type A with reinforced immunity to transient phenomena. (cf. p. 29)

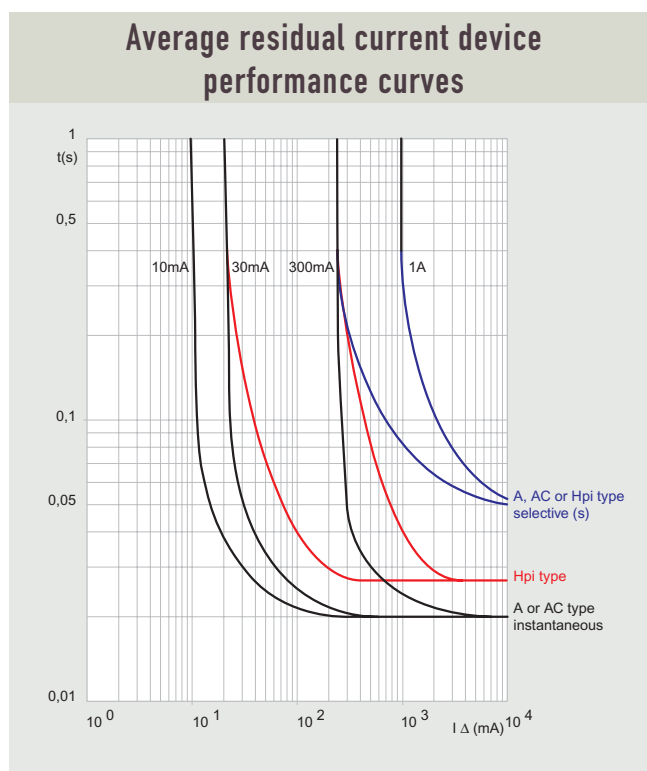

### Advantages of residual current devices

The total assurance of the protection provided by neutral earthing systems depends both on the design (calculation) rules, construction (lengths of lines, quality of the earths) and above all on upgrades to and use made of the installation (extensions, mobile loads). In the face of this uncertainty, and the eventual risk of a reduction in the level of safety, the use of residual current devices represents a “solution” that can be used in addition to earth connection schemes.

- **Medium sensitivity (300 or 500 mA).** This avoids the rise in the energy of fault currents that may cause a fire (protection of property).

- **High sensitivity (30 mA).** This maintains protection against indirect contact if the earth is poor or the protective conductor is broken. It is used in addition to protection against direct phase/earth contact (protection of people).

# Protection by residual current devices (continued)



## False tripping

### Causes

- **Leakage currents:**

LV electrical installations have permanent leakage currents, which are not due to faults, but to the actual characteristics of the insulation of the devices and the conductors. They are generally a few milliamperes in an installation in a good state of repair and do not cause any unwanted tripping.

The development of receivers integrating increasing amounts of electronics with associated switching mode power supplies and filtering is leading to higher leakage currents.

A single computer terminal incorporating several devices (CPU, screen, printer, scanner, etc.) may have a leakage current of a few milliamperes. Supplying several terminals from the same socket or the same circuit can therefore quickly lead to a total leakage current that causes high sensitivity residual current devices to trip.

- **Transient currents:**

The capacitive effects of the installation, switching overvoltages on inductive circuits, electrostatic discharges or lightning strikes are all momentary phenomena which are not faults in the real sense, and against which the residual current devices must be rendered immune.

- **Presence of DC components:** DC components may circulate following the failure of certain electronic power supplies. These may alter or even destroy the operation of residual current devices if they are not protected accordingly.

### Solutions

- **High leakage currents:**

- Divide the circuits and protect them separately so as to limit the number of devices for each of them, ensuring there is vertical discrimination
- Use class II devices when they are available
- Supply devices with a high risk of leakage via a separation transformer
- Use Hpi type residual current devices with the most appropriate tripping curve
- Apply the "special use exemption measure" only as a last resort (see previous page).

- **Transient currents:**

- Limit these by ensuring good equipotentiality of the installation (cf. book "Protection against external disturbances")
- Use cables with a protective conductor connected to earth, even if this conductor is not used (supply of class II equipment), as cables without a protective conductor can generate transients by capacitive effect
- Use delayed residual current devices (type s), which allow transient currents to pass during the delay phase, or preferably Hpi residual current devices which provide good immunity to transient currents (limiting of trips) while maintaining maximum safety of the protection (speed).



## Hpi (high level of immunity) residual current devices

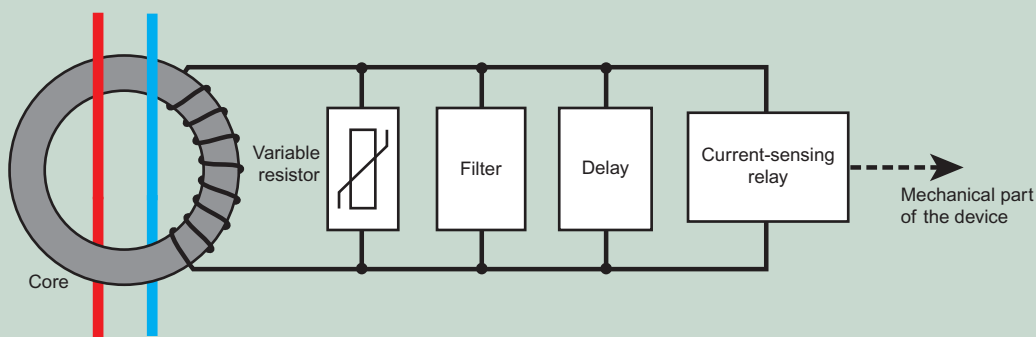

- The nanocrystalline ferromagnetic alloy core, with low remanence and high saturation, detects faults on signals with DC components (rectified power supplies).
- The variable resistor eliminates very high current transient phenomena (lightning strikes, switching overvoltage on HV supply).
- The filter attenuates interference due to high frequencies (switching mode power supplies).
- The 10 ms time delay absorbs transient overvoltages (activation on inductive or capacitive loads, capacitive discharges).

Hpi residual current devices provide better protection for people.

- They ensure tripping within a time less than the maximum specified by standard IEC 61009-1 despite the 10 ms time delay.
- Hpi residual current devices operate under extreme conditions (down to  $-25^{\circ}\text{C}$ ).
- They detect residual current faults with DC components: Hpi residual current devices are type A.
- They have a good response at high frequencies (tripping in 300 ms max. at 1 kHz).
- Fault detection is not disturbed by high frequency signals (no "blinding" of the residual current device).

Legrand Hpi residual current devices are particularly designed for the protection of power socket circuits for computer terminals. Their high level of immunity means that they avoid data being lost due to false tripping, even when the installation is exposed to transient interference and there are a large number of terminals per residual current device. They therefore avoid the need for exemption from protection or more residual current protection devices.



< DX Hpi RCD

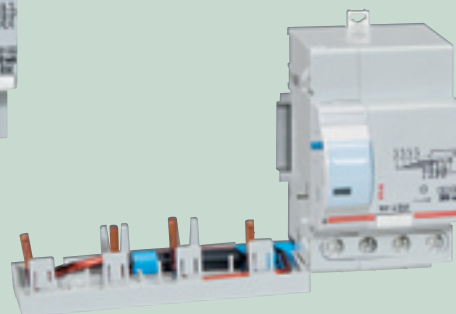

^ Add-on Hpi module

# Protection by residual current devices (continued)

## DISCRIMINATION BETWEEN RESIDUAL CURRENT DEVICES

The conditions for coordination of residual current protection devices (RCD) are defined by IEC 60364-5-53. While ensuring maximum safety, they allow continued operation of those parts of the installation not affected by any faults that may occur. Discrimination between two residual current protection devices requires the time/current non-tripping characteristic of the upstream device to be higher than that of the downstream device.

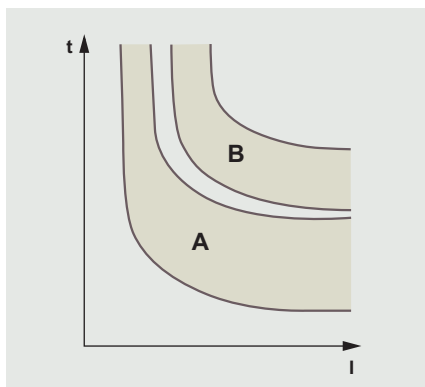

Total discrimination between a downstream device (A) and an upstream (B) device

### 2 and 3 level discrimination

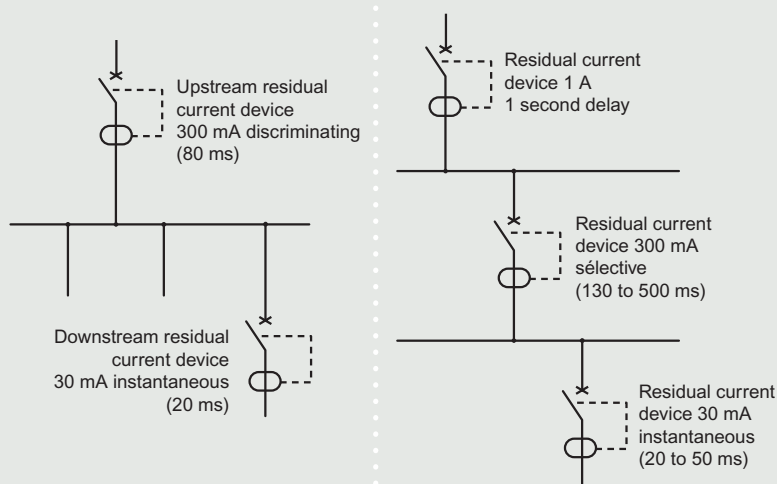

**In practice, the upstream device should have a sensitivity 2 to 3 times lower and a breaking time at  $I_{\Delta n}$  at least 4 times longer than the downstream device.**

**Example: with a 1 A fault current**

- Downstream device: 30 mA instantaneous (tripping in 20 ms)
  - Upstream device: 300 mA discriminating (tripping in 80 ms)
- Caution: usually, a delay of more than 1 s is not permitted.**

## REQUIREMENT FOR CLASS II

It is necessary to making the installation a particular class II when protection against indirect contact may not be provided on certain parts of the installation, for example:

- The connection panels of installations with a TT system in which the main device does not have a residual current function

- Panels where the presence of a voltage surge protector at the supply end would lead to the tripping of a main residual current device
- Circuits in which the time/current characteristics of the residual current devices are not compatible with the local earth connection resistance.





**Maximum earth connection resistance value  $R$  ( $\Omega$ ) according to the operating current of the residual current device (tripping time not more than 1 s).**

$I\Delta n$ RCD	R earth ( $\Omega$ ) $R_L: 50 V$
30 mA	> 500
100 mA	500
300 mA	167
500 mA	100
1 A	50
3 A	17



The installation must be class II up to the output terminals of the residual current devices, providing effective protection against indirect contact (time/current characteristics compatible with the local protection conditions defined by the permitted touch voltage  $U_L$  and the resistance  $R$  of the earth connection).

### Example of class II treatment

**Non residual current connection device**

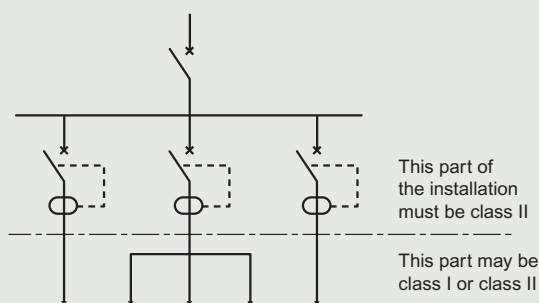

**Voltage surge protector placed upstream of the residual current device**

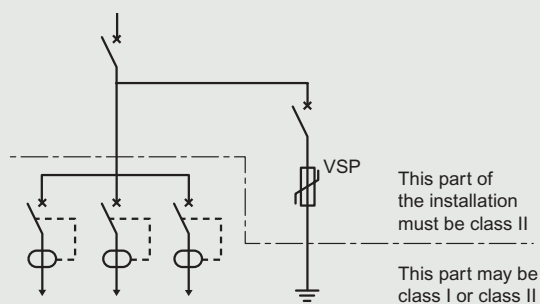

**4 levels of discrimination, the first two of which require class II installation**

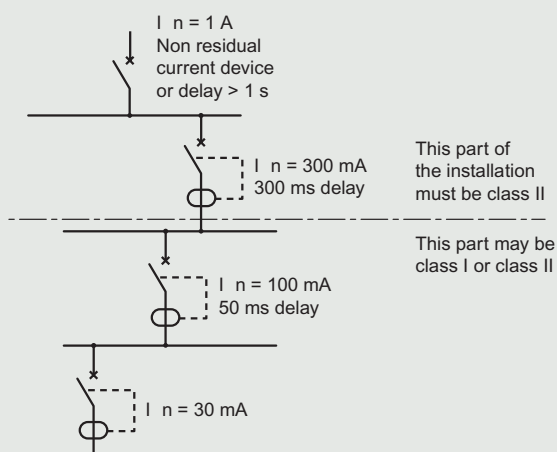

**Main outgoing line to another class II**

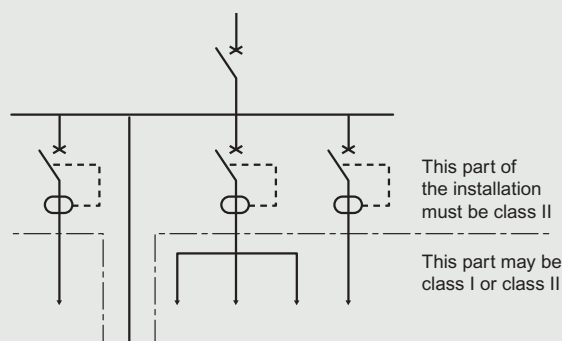

# Protection provided by assemblies

Manufacturers in general, and Legrand in particular, are responsible for constructing their devices. Details on conformity to standards, the statutory aspect, instructions for installation and use accompany all products. But choosing the right ones for the actual conditions, their preparation, using them together and integrating them in complex installations, require the expertise of professional electricians. And many of the rules for this are unwritten, particularly for execution of assemblies and distribution panels.

## CLASS I ASSEMBLIES

The rules described below summarise the requirements of standards EN 60204-1, EN 60439-1, IEC 60364, IEC 1140 and common sense recommendations for construction.

All parts that can be directly accessed by the user are considered to be exposed conductive parts, even if they are covered with paint or coatings, unless these prove to have insulating qualities that are known and tested at the thickness applied (example: film bonded to the part). The concept of exposed conductive parts is also extended to all metal parts that are inaccessible to the user but can be accessed by a worker, even a qualified worker, including after dismantling, due to the fact that their layouts or dimensions lead to an appreciable risk of contact (examples: rails, plates, device supports, etc.). It is also extended to intermediate metal parts that are inaccessible but are in mechanical contact with the exposed conductive parts, due to the fact that they can spread a voltage (example: mechanism transmissions). Parts that are totally inaccessible (to staff either using them or working on them), exposed conductive parts which, due to their small size (less than 50 x 50 mm) cannot come into contact with the body (unless they can be gripped by the fingers or held in the hand), contactor cores, electromagnets, etc. are not considered to be exposed conductive parts and do not have to be connected to a protective conductor.

### Connection of the exposed conductive parts of a class I assembly

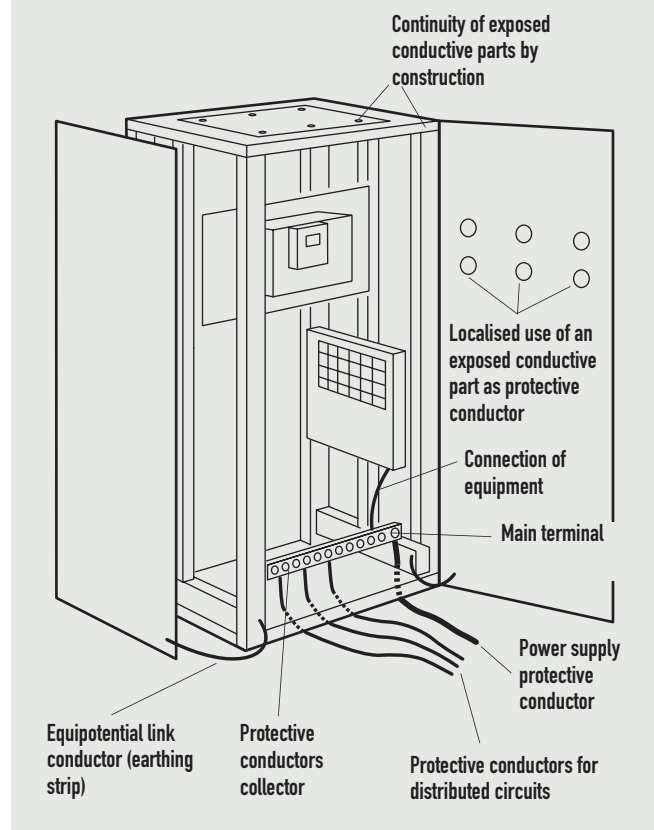

## 1 CONNECTION OF PROTECTIVE CONDUCTORS

The collector of the protective conductors, marked with the symbol  $\oplus$ , is connected to the chassis or the main structure. It has a terminal for connecting the protective conductor of the power supply. This terminal must be sized to take a conductor with the cross-section defined in the table below. The protective conductors of the load circuits are connected to the same collector. Their tap-off at the same clamping point is not permitted. With the exception of the collector bars of power assemblies designed to be connected via terminals, a single tapped hole or a tag for solder connector are not considered to be adequate. The need to scrape off paint or remove a covering is not permitted.

Minimum cross-section of the protective conductor ( IEC 60364-5-54)	
Cross-section of supply phase conductors $S$ (mm <sup>2</sup> )	Minimum cross-section of the corresponding protective conductor $S_{PE}$ (mm <sup>2</sup> )
$S \leq 16$	$S$
$16 < S \leq 35$	16
$35 < S \leq 400$	$S/2$
$400 < S \leq 800$	200 <sup>(1)</sup>
$S > 800$	$S/4$ <sup>(1)</sup>

(1) EN 60439-1

## 2 EQUIPOTENTIALITY OF EXPOSED CONDUCTIVE PARTS

Exposed conductive parts must be electrically connected to one another so that no dangerous voltage can arise between exposed conductive parts that are simultaneously accessible. This continuity can be obtained by construction or by using equipotential link conductors.

### 2.1. Continuity of exposed conductive parts by construction

This must be effectively protected against mechanical and chemical damage. The electrochemical compatibility of the metals must be checked (see table in the book "Protection against external disturbances"). Dismantling an element must not lead to discontinuity of the link. The exposed conductive parts must not therefore be connected "in series". As far as possible the electrical connection must be dependent on the mechanical fixing (for example, common screw), in such a way that the second function cannot be achieved without the first.



> XL<sup>3</sup> supports provide continuity of the exposed conductive parts by construction

Redundancy of the connection points is recommended. For covers, plates and similar parts, metal fixings, screws, bolts and rivets are considered to be adequate if all traces of paint have been removed and if no electrical equipment (without its own protective conductor) is fixed to them.

Systems using clips, pins, washers with pins or grooved rivets that pierce the surface coating must be checked in accordance with the continuity test (cf. p. 37).

# Protection provided by assemblies (continued)

## 2.2. Continuity of exposed conductive parts by equipotential link conductors

When the exposed conductive parts (door, protective screen, closing panel, etc.) do not support any devices or equipment, the equipotential connection of these exposed conductive parts must be provided using a conductor, minimum cross-section  $2.5 \text{ mm}^2$ , if it is protected mechanically (conductor in a multi-core cable, conductor insulated in a protective sleeve, conductor attached along its entire run).

This cross-section must be increased to  $4 \text{ mm}^2$  if the link conductor is not protected or if it is subject to repeated operations (opening of a door, handling). The connections of this conductor must themselves have a reliable contact with the connected exposed conductive parts (paint removed, protection against corrosion and loosening). The continuity must be checked in accordance with the methods described on page 37.

NB: The equipotential connections created by conductors are generally independent of the mechanical functions and may for this reason not be re-connected after maintenance work has been carried out. To limit the risk of this happening, the links must if possible be close to the fixings and must be unambiguously labelled: conductors with dual green/yellow colouring or marked at both ends using these colours and marking near the  $\oplus$  connections.

## 2.3. Connection of equipment

When devices or equipment are fixed on exposed conductive parts, and in particular when these parts are removable (doors, panels, plates, etc.), the equipment that is fixed on must be connected directly with a protective conductor if it has a terminal for this purpose. The cross-section of this conductor will be selected according to that of the phase conductors supplying the device concerned, in accordance with the table on page 33. The PE conductor terminals must not be used for any other functions (for example, mechanical fixing).

## 3 USING THE EXPOSED CONDUCTIVE PARTS AS PROTECTIVE CONDUCTOR

This type of use is permitted as long as a number of precautions are taken, but localised or specific application must nevertheless be distinguished from general or systematic application according to how widely this measure is used.

Exposed conductive parts used as protective conductors must have a conductance that is sufficient and equivalent to that which would result from the use of copper conductors. This characteristic must be checked using the tests described on page 37 (continuity of exposed conductive parts and resistance to overcurrents).

Any links between the various parts must be protected against mechanical, chemical and electrodynamic damage. The risk of dismantling a part which would lead to the protective circuit being broken must be limited:

- Either by combining an essential function with the electrical connection so that the device or equipment cannot operate normally or so that it is obviously incomplete on visual inspection
- Or by limiting the number of parts that make up the protective circuit to only one in the case of a localised measurement application
- Or by only using the structure, frame or main chassis of the device or equipment in the case of a generalised application.

**Minimum cross-section of equipotential link conductors (IEC EN 60439-1)**

Rated operating current(A)	Minimum cross-section of equipotential bonding conductor ( $\text{mm}^2$ )
$I_e < 25$	2.5
$25 < I_e \leq 32$	4
$32 < I_e \leq 63$	6
$63 < I_e \leq 80$	10
$80 < I_e \leq 160$	16
$160 < I_e \leq 200$	25
$200 < I_e \leq 250$	35

### 3.1. Localised use of an exposed conductive part as protective conductor

This measure is generally used when one or more devices that do not have a connection terminal for a proper protective conductor (indicators with metal bases, metal operating mechanisms, etc.) are fixed onto a part such as a cover, panel, door, etc.

In addition to the general rules that have already been defined, the following precautions must also be taken:

- The electric contact between the support element and the device (or devices) must be treated to ensure it is reliable (paint removed, protection against

corrosion, resistance to loosening, etc.)

- The additional equipotential link between the support element and the main protection circuit (whether this is created using exposed conductive parts or conductors) must be sized according to the maximum current, which is equal to the sum of the currents of each of the devices fixed on, in accordance with the table on page 34. The value of the shortcircuit current will be limited to that corresponding to the power supply of the most powerful device fixed onto the part.



#### Equivalent cross-section of the steel support rails used as protective conductors

As long as they are totally interconnected by their assembly and connected using appropriate Viking terminal blocks, fixing rails (commonly known as DIN rails) can be used as protective conductors.



Viking terminal blocks provide an excellent quality connection with the rail, with a resistance in the region of 1 mΩ. The component parts are designed to resist mechanical forces and have no internal stresses. They are protected against corrosion. The equivalent conductivity of the support rails used conforms to the determination rules in standards

IEC EN 60947-7-2. It is certified by report LCIE 285380. Viking terminal blocks can only be removed from the rail using a tool, and cannot be turned off.

Viking terminal blocks for protective conductors have been specially designed and tested for the defined use. They conform to standards IEC 6947-7-2, UL 1059, UL 467 and CSA 22-2.

It is important to emphasize that the use of a steel rail as a PEN conductor is not permitted by standard IEC 60364-5-54. In other words, permanent circulation of a current between the conductor(s) and the steel rail is prohibited. This is why no nominal current (I permanent) is given for and on these blocks. This application is however permitted for copper or aluminium rails (IEC 60947-7-2).

Type of rail according to standard EN 60715	Equivalent cross-section in Cu (PE conductor)
Top hat rail TH 35 x 5.5	10 mm <sup>2</sup>
Top hat rail TH 35 x 7.5	16 mm <sup>2</sup>
Legrand top hat rail TH 35 x 15 (non-standard thickness 1,5 mm)	35 mm <sup>2</sup>
Top hat rail TH 35 x 15 (standard thickness 2 mm)	50 mm <sup>2</sup>
asymmetric rail G 32	35 mm <sup>2</sup>

# Protection provided by assemblies (continued)

## 3.2. Generalised use of the exposed conductive parts as protective conductors

This measure can be applied when there is a continuous conductive structure large enough to interconnect the other exposed conductive parts and the equipotential link conductors. Connection devices or means of connection must therefore be provided accordingly, even for devices that may be installed in the future (as is the case with assemblies of enclosures, for example).

The equivalent cross-section  $S$  must allow any possible short circuit current to be carried, calculated based on the maximum current limited by the device protecting the equipment's power supply, and the breaking time of this device.

$$S = \frac{\sqrt{I^2 t}}{K}$$

$S$ : cross-section of the protective conductor in  $\text{mm}^2$

$I$ : rms value of the fault current in A

$t$ : operating time of the breaking device in s

$K$ : coefficient depending on the permitted temperatures, the metal used and the insulation (a value of  $K = 50$ , corresponding to a temperature rise of steel of  $80^\circ\text{C}$ , can generally be used).

If the possible fault loop, or even the protection device, is not known (which is generally the case with "empty" enclosures and cabinets), a check must be carried out to ensure that the equivalent conductive cross-section

of the material used is at least equal to that of the copper protective conductor required for the installed power (see table on page 33). In practice, the copper equivalent cross-section for the materials used can be checked using the formula:  $S_{\text{material}} = n \times S_{\text{copper}}$  (only valid for similar temperature and installation conditions). Where  $n = 1.5$  for aluminium,  $n = 2.8$  for iron,  $n = 5.4$  for lead,  $n = 2$  for brass (Cu Zn 36/40).



**In general, installation standards (such as NFC 15-100 in France for example) do not accept the use of the following metallic elements to serve as protective or equipotential conductors:**

- cable trays and similar products,
- ducts for fluids (i.e. water, gas, heating, etc.),
- building structural elements,
- conductor-carrying cables.

**Some countries (such as Italy) do accept the use of cable trays for this purpose. In that case, however, continuity must be ensured according to the terms of the IEC 61-537 standard, which implies conditions that, over significant lengths of assembly, are very difficult, sometimes in fact impossible, to attain. The option can not therefore be advised.**

**Note that this restriction does not exclude the connection of such elements to the equipotential system.**

## 4 CHECKING THE CONTINUITY OF THE EXPOSED CONDUCTIVE PARTS

The resistance of the protection circuit is checked between the main terminal connecting the protective conductor and any exposed conductive part on the device or equipment. It is measured using the voltamperometric method or using a micro ohmmeter passing a 50 Hz AC current through it for at least 10 s. The resistance must be measured (or calculated) for a 25 A current. It must not exceed 0.05 Ω.

NB: This value does not take into account possible equipotentiality requirements linked to electromagnetic compatibility which would require much lower impedance levels (of the order of one milli-ohm). See the book "Protection against external disturbances".

## 5 CHECKING RESISTANCE TO OVERCURRENTS

### 5.1. Protective conductors and exposed conductive parts used as protective conductors

These are subjected to a short circuit current that is defined as follows:

- Either based on the thermal stress  $I^2t$  limited by the protection device by applying an  $I_{cw}$  value equal to  $\sqrt{I^2t}$
- Or by applying a value equal to that of the maximum thermal stress permitted by the protective conductor necessary for the equipment or the equipment part concerned, when the protection device is not known. The test current  $I_{cw}$  for 1 s is then equal to  $\sqrt{k^2 S^2}$  (see table in chapter "Protection against short-circuits" in the book "Dimensioning conductors and determining protection devices").

### 5.2. Exposed conductive parts accidentally energised as a result of a conductor becoming detached

Although the probability of this happening is low, it must nevertheless be taken into consideration for equipment supplied via a supply with a TN or IT neutral earthing system that does not have any additional residual current protection. If there is a fault between phase(s) and metal parts connected to the protective conductor, this situation can lead to the circulation of a short-circuit current that is only limited by the overcurrent protection devices. In an IT system, this risk only arises at the 2nd fault on another phase, and the short-circuit current remains lower than in a TN system. In such applications, the exposed conductive parts concerned, the equipotential connections and their connection to the protective conductor must be checked to ensure they are able to carry the fault current limited by the protection device at a current equal to 60% of the prospective 3-phase  $I_{sc}$ .

The limited thermal stress value  $I^2t$  will determine the test current, equal to  $\sqrt{I^2t}$  for 1 s.

As a guide, the  $I_{cw}$  test values according to the ph/PE fault current in the table below can be used.

Value of the test current according to the fault current		
Fault current ph/PE (kA)	Test current $I_{cw}$ (A)	Main device
3	200	DX $I_n \leq 63$ A
6	250	DX $63 < I_n \leq 125$ A
10	700	DPX $I_n \leq 125$ A
15	1000	DPX $125 < I_n \leq 400$ A
20	2000	DPX $I_n > 400$ A
35	3800	DPX $I_n \leq 1000$ A

# Protection provided by assemblies (continued)

## CLASS II ASSEMBLIES

Only enclosures made of insulating materials can be referred to as having “total insulation protection”: these are designated class II A.

This does not preclude metal enclosures from also being able to provide a level of safety equivalent to class II.

These enclosures are then designated class II B. On the other hand, an insulated enclosure is not necessarily class II. It may, for example, be class I if the metal parts or devices it contains are connected to a protective conductor.

### Provisions of section 558 of NF C 15-100

**Class II A with insulated enclosure:**  
no special measures to be taken.

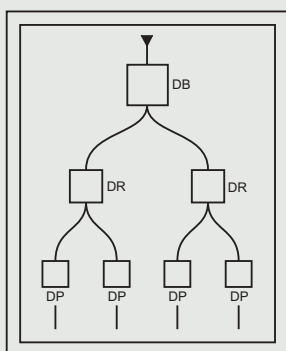

**Class II B with metal enclosure:**  
equipment that is not class II must be separated by additional insulation.

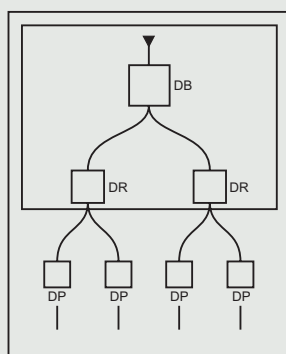

**Class I with part class II:** the part upstream of the RCDs is created using class II equipment and/or additional insulation.

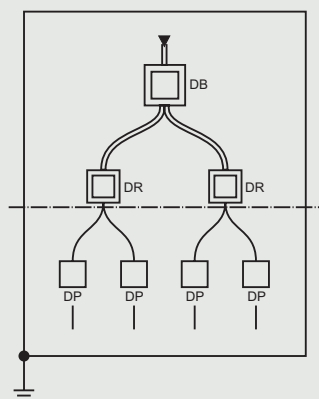

**DB:** non residual current incoming circuit-breaker  
**DR:** residual current device  
**DP:** overcurrent protection device (fuses, circuit-breakers)



## 1 CLASS II A ENCLOSURES

### 1.1. Continuity of the insulating protection

The enclosure must be designed in such a way that no fault voltage can be transmitted to the outside. It must provide a degree of protection when installed of at least IP 2xC according to standard IEC EN 60439-1. This continuity of protection must also be ensured on the sides that are not accessible (for example, flush-mounted box) if there is a risk of contact, even accidental (detached conductor), with an external conductive element such as a metal structure or masonry structure. In this specific case, these degrees of protection must be checked from the inside of the product to the outside.

This level of protection can be limited to IP 2x (risk of penetration of animals), if measures designed to prevent any movement of the conductors are implemented (cf. p. 40).

If conductive parts must be passed through the enclosure, whatever their size (device controls, locks, hinges, rivets, wall mounting lugs, etc.), these should preferably be insulated inside the enclosure so that they cannot become energised as a result of a fault. It must not be possible to replace isolating screws with metal screws if this adversely affects the insulation.

### 1.2. Chassis and internal metal parts

These must not be connected to the protective conductor and must not be in electrical contact with parts that pass through the enclosure. There must be clearly visible  marking inside and outside the enclosure.

If, for functional reasons, an earth connection is necessary (EMC), this must not be identified with dual green/yellow colouring (black is conventionally used) and the terminal(s) must be labelled E or with the symbol  (cf. book "Electrical energy supply"). Additional explanations (manual, technical documents) must be provided.

For assemblies where there is a risk of unintentional connection to the protective conductor (chassis, bar, collector, etc.) or connection in the future (maintenance, upgrading of the installation, etc.), a warning of the following type must be affixed: "Caution, double insulated assembly - Exposed conductive parts not connected to the protective conductor".

The chassis and metal parts inside the enclosure must be considered as being potentially dangerous, even for qualified people, if there is a failure of the main insulation of the devices enclosed or if a conductor becomes detached. In practice such a risk can be limited by only incorporating devices that are class II (including terminal blocks, distributions, etc.) or have equivalent insulation in relation to these chassis and metal parts (therefore similar to accessible exposed conductive parts), and by treating the conductor wiring (see "Additional insulation on the installation" on the next page).

**Marina II >  
IP 66 class II cabinets  
and enclosures,  
can be fitted with  
a distribution chassis**



# Protection provided by assemblies (continued)

## 2 CLASS II B ENCLOSURES

Class II B can be achieved using structural measures or with additional insulation on the installation.

### 2.1. Structural measures

The internal surface of the enclosure is covered with a continuous insulating coating up to where the conductors enter. Insulating barriers surround all the metal parts where accidental contact could occur. The devices, connections and all the equipment installed must provide clearances and creepage distances between the enclosure and the dangerous parts (live parts, conductors and PE terminal, metal parts only separated by functional insulation) under all, including accidental, circumstances (pulling out of a conductor, loosening of the terminals, movement caused by a short-circuit).

### 2.2. Additional insulation on the installation

This measure can be used for metal cabinets and enclosures located at the source of the installation (LV distribution board) and in particular for the part between the source of the installation and the output terminals of the residual current devices protecting the outgoing lines.

Standardisation provides the possibility of obtaining a safety level equivalent to class II by giving the devices additional insulation on the installation: insulating spacers, insulation of support rails, etc. These theoretical measures are difficult to put into practice and often not very appropriate for industry. It is therefore preferable, here too, to only use equipment that is itself class II, with insulation treatment thus being limited to the conductors and cables. Unless the latter are class II or considered equivalent (U1000 R 2V, H07 RN-F, etc.), they must be placed in insulated conduits or ducting. Cable guide systems, rings or even stranding with clamps may be adequate if they provide a hold that prevents any accidental

contact with the enclosure. Conductors and cables can be kept close to connections, even if they come loose, by the use of appropriate terminal covers. Systems with several simultaneous connection points (supply busbars) are considered as not being able to move.

## 3 PROTECTIVE CONDUCTORS (PE)

If one or more protective conductors and their terminals are protected by the enclosure, they must be totally isolated from the live parts, metal parts and chassis. Even if the devices in the enclosure have terminals for PE conductors, they must not be connected. This measure does not prevent equipotential bonding conductors connecting the exposed conductive parts of the devices to one another for functional reasons, as long as these links are not themselves connected to the protective conductor. If an external ground terminal has to be installed, it must be clearly identified by the symbol  $\overline{h}$ , together with the symbol  $\otimes$ .

The protective conductors and their terminals will be protected in the same way as live parts and must therefore have IP xxB protection (or xxA with terminal cover if  $> 16 \text{ mm}^2$ ) when the door of the enclosure is open. It may be necessary to provide protective covers to limit the risks of mutual contact with conductors that only have main insulation (wiring conductors) and/or the risks of accidental contact with a detached conductor.

## 4 CHECKING THE DIELECTRIC PROPERTIES

By construction, the insulation characteristics of the enclosures should not be affected by the operational stresses that are likely to reduce them (mechanical shocks and impacts, rain, dripping water, pollution and conductive deposits, corrosion, etc.). The insulation tests consist of applying the following voltages.

- 1st test: test voltage at industrial frequency (detection threshold 10 mA):
  - One minute at 3750 V for enclosures with insulation voltage  $\leq 690$  V
  - One minute at 5250 V for enclosures with insulation voltage  $\leq 1000$  V.
- 2nd test: impulse test voltage (wave 1.2/50  $\mu$ s), 3 times for each polarity:
  - 6 kV for enclosures with insulation voltage  $\leq 690$  V
  - 8 kV for enclosures with insulation voltage  $\leq 1000$  V.

These voltages are applied in the following way.

- 1st test: Between metal foil representing the external access surface and all the internal parts of the enclosure connected to one another (live parts, chassis and metal parts, screws, inserts, closing devices and protective conductors). Applied over the whole external surface, including the back, the metal foil can be pushed with a standardised test finger, it must also be connected to the enclosure's screws or fixing components.
  - 2nd test: Between all the internal parts of the enclosure connected to one another (live parts, chassis and metal parts, screws, inserts, closing devices, etc.) and the protective conductors and their terminals.
- NB: When the internal parts or their locations are not clearly identified ("empty" enclosures and cabinets, boxes, ducting, conduits, etc.), they can be represented by metal foil applied on the inner surface, by filling the internal space with conductive balls, by applying conductive paint, or by any other representative means.
- The tests must not cause either flashover, breakdown or perforation.



**Industrial frequency >  
generator for insulation test**

# Choice of products



6021 93



091 47

## RCDs

### RCDs LR™

Sensitivity	In (A)	AC type		A type	
		2-pole - 230 V~	4-pole - 400 V~	2-pole - 230 V~	4-pole - 400 V~
30 mA	25	6021 36	6021 46		
	40	6021 37	6021 47	6021 93	6021 94
	63	6021 38			6021 95
100 mA	25	6021 39	6021 49		
	40	6021 40	6021 50		
300 mA	25	6021 42			
	40	6021 43	6021 52		
	63	6021 44	6021 53		

### RCDs DX™

Sensitivity	In (A)	AC type			A type			Hpi type	
		2-pole 230 V~	4-pole - 400 V~		2-pole 230 V~	4-pole - 400 V~		2-pole 230 V~	4-pole 400 V~
			Neutral on right-hand side	Neutral on left-hand side		Neutral on right-hand side	Neutral on left-hand side		
10 mA	16	089 06			090 53				
30 mA	25	089 09	089 93	086 93	090 56	091 40	090 98	088 22	6021 08
	40	089 10	089 94	086 94	090 57	091 41	090 99	088 23	6021 09
	63	089 11	089 95	086 95	090 58	091 42	091 00	088 24	6021 10
	80	089 12	089 96		090 59	091 43			
	100	6027 10				091 44			
100 mA	25	089 15	089 99			091 46			
	40	089 16	090 00			091 47			
	63	089 17	090 01			091 48			
	80	089 18	090 02			091 49			
						091 50			
300 mA	25	089 27	090 11		090 74	091 58			
	40	089 28	090 12		090 75	091 59			
	63	089 29	090 13		090 76	091 60			
	80	089 30	090 14		090 77	091 61			
	100	6027 12				091 62			
300 mA (s)	40		090 18			091 65			
	63		090 19			091 66			
500 mA	25		090 23			091 71			
	40		090 24			091 72			
	63		090 25			091 73			
	80		090 26			091 74			



6064 00



078 86



079 80

## RCBOs

### RCBO DX™ **6 000** - 10 kA and DX™ **10 000**

Sensitivity	In (A)	AC type				A type		
		Single pole - 230 V <sub>~</sub>		Single pole + neutral 230 V <sub>~</sub>	2-pole 230 V <sub>~</sub>	4-pole 400 V <sub>~</sub>	Single pole + neutral 230 V <sub>~</sub>	4-pole 400 V <sub>~</sub>
		Black neutral lead	Blue neutral lead					
10 mA	3			078 79	077 45		085 75	
	10				077 46			
	16				077 47			
	20							
30 mA	3			078 81				
	6			078 83			085 79	
	10	6064 00	6064 10	078 84	079 11	079 62	085 85	080 75
	16	6064 01	6064 11	078 86	079 19	079 64	085 87	080 76
	20	6064 02	6064 12	078 87	079 20	079 65	085 88	080 77
	25	6064 03	6064 13	078 88	079 21	079 66	085 89	080 78
	32	6064 04	6064 14	078 89	079 22	079 67	085 90	080 79
	40			078 90	079 29	080 13	085 91	
	45	6064 05	6064 15					
	50				079 30	080 14		
63				079 31	080 15			
300 mA (s)	6			078 94				
	10			078 95	079 44	079 75		080 84
	16			078 97	079 46	079 77		080 85
	20			078 98	079 47	079 78		080 86
	25			078 99	079 48	079 79		080 87
	32			079 00	079 49	079 80		080 88
	40			079 01	079 50	080 31		
	50				079 51	080 32		
63				079 52	080 33			



075 76

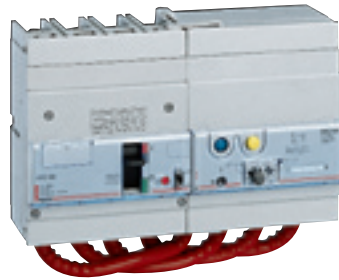

251 33



260 55

## ADD-ON MODULES

### Add-on modules for DX, DX-H, DX D

Sensitivity	In (A)	AC type			A type			Hpi type		
		2-pole 230/400 V $\sim$	3-pole 400 V $\sim$	4-pole 400 V $\sim$	2-pole 230/400 V $\sim$	3-pole 400 V $\sim$	4-pole 400 V $\sim$	2-pole 230/400 V $\sim$	3-pole 400 V $\sim$	4-pole 400 V $\sim$
30 mA	32	074 01	074 28	074 55	074 83		075 37			
	63	074 02	074 29	074 56	074 84	075 11	075 38	075 64	075 68	
	80-125	074 03		074 57	074 85		075 39		075 69	
300 mA	32	074 07	074 34	074 61	074 89		075 43			
	63	074 08	074 35	074 62	074 90	075 17	075 44			075 74
	80-125	074 09	074 36	074 63	074 91	075 18	075 45			
300 mA (s)	63	074 11	074 38	074 65	074 93	075 20	075 47			
	80-125			074 66						
1 A	63	074 23	074 01	074 77						
	80-125		074 01	074 78						

### Add-on modules for DX-L

Sensitivity	Hpi type		
	2-pole - 230/400 V $\sim$	3-pole - 400 V $\sim$	4-pole - 400 V $\sim$
30 mA	075 76	075 80	075 84
300 mA	075 77	075 81	075 85
300 mA (s)	075 78	075 82	075 86
1 A (s)	075 79	075 83	075 87

### Electronic earth leakage modules for DPX (Adjustable sensitivity: 0.03 - 0.3 - 1 - 3 A)

Device	In (A)	3-pole		4-pole	
		mounted side by side	mounted underneath	mounted side by side	mounted underneath
DPX 125	63	260 02		260 03	260 04
	125	260 12		260 13	260 14
DPX 160	160	260 20		260 21	260 22
DPX 250 ER	160			260 31	260 33
	250			260 36	260 38
DPX 250	160				260 51
	250		260 54		260 55
DPX 630	400		260 60		260 61 260 63 <sup>(1)</sup>
	630		260 64		260 65 260 67 <sup>(1)</sup>

## POWER GUIDE: A complete set of technical documentation



01 | Sustainable development



08 | Protection against external disturbances



02 | Power balance and choice of power supply solutions



09 | Operating functions



03 | Electrical energy supply



10 | Enclosures and assembly certification



04 | Sizing conductors and selecting protection devices

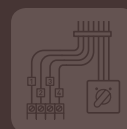

11 | Cabling components and control auxiliaries



05 | Breaking and protection devices

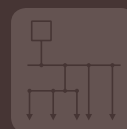

12 | Busbars and distribution



06 | Electrical hazards and protecting persons



13 | Transport and distribution inside an installation



07 | Protection against lightning effects



Annexes  
Glossary  
Lexicon



**World Headquarters and International Department**  
87045 Limoges Cedex-France  
☎ : + 33 (0) 5 55 06 87 87  
Fax : + 33 (0) 5 55 06 74 55